

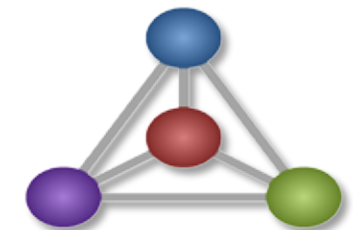

# Certification Training 1 - Fundamentals

2 November 2020



**Pragmatic**  
ENTERPRISE ARCHITECTURE  
CONNECTING THE DOTS™

# What are Pragmatic Frameworks used for?



**Pragmatic**

**Family of  
Frameworks**



## **Keypoint**

PF2 introduces the Companies and Frameworks that are part of the Pragmatic Family.

## **Adoption**

Management: Instigate a project to ensure everyone related to Transformation is trained in Pragmatic's Family of Frameworks.

# What does the Introduction section of PF2 contain?

# Introduction

**Keypoint**  
The Introduction section of PF2 introduces the companies that are part of the Pragmatic Family.

# What do Pragmatic 365 Ltd and Pragmatic EC Ltd Do?

## Pragmatic 365

- Research (non-profit)

Creates this

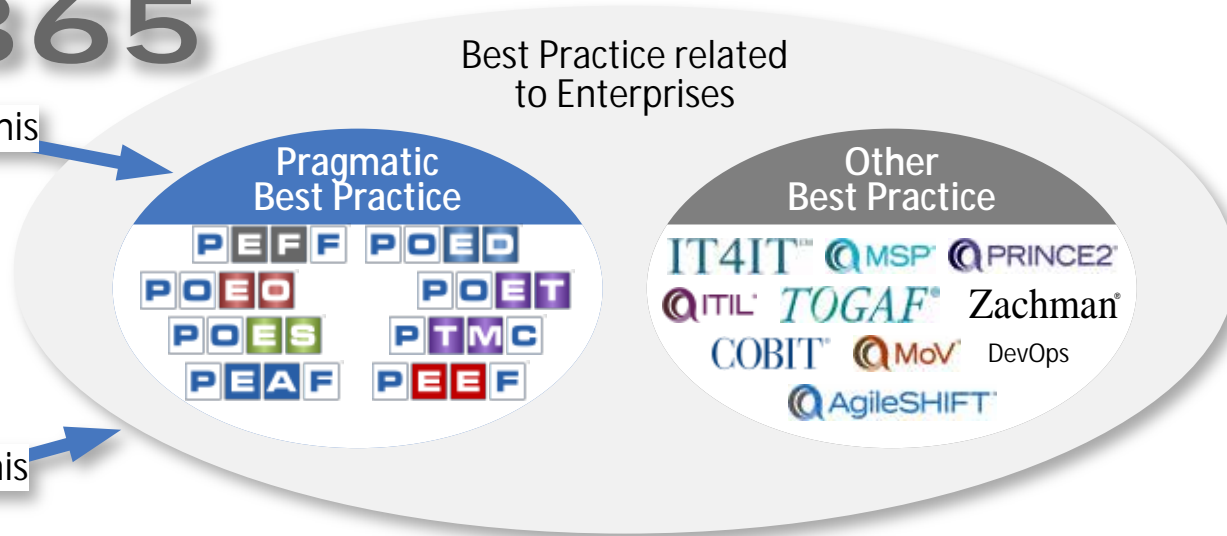

Uses this

## Pragmatic EC

- Consulting
- Training
- Mentoring
- Publishing

To mature this

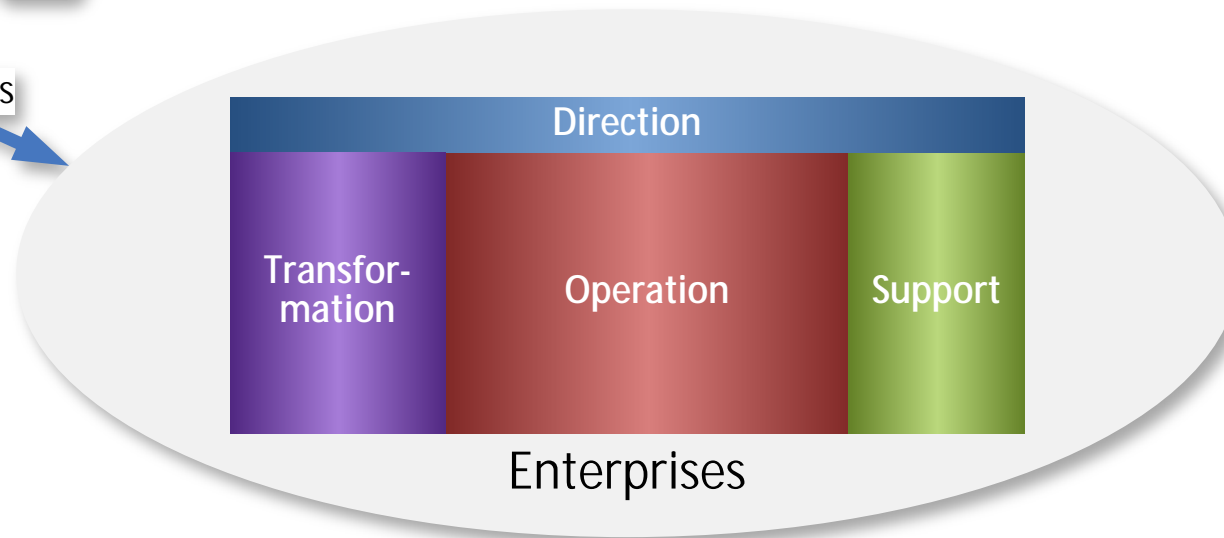

### Keypoint

Pragmatic 365 is a non-profit research company. Pragmatic EC is a consulting company.

### Adoption

Management: Engage Pragmatic EC to assess and help you to mature your Enterprise's Transformation capability.





# How is Pragmatic EC different to most other consultancies?

## The Transformation of Transformation™

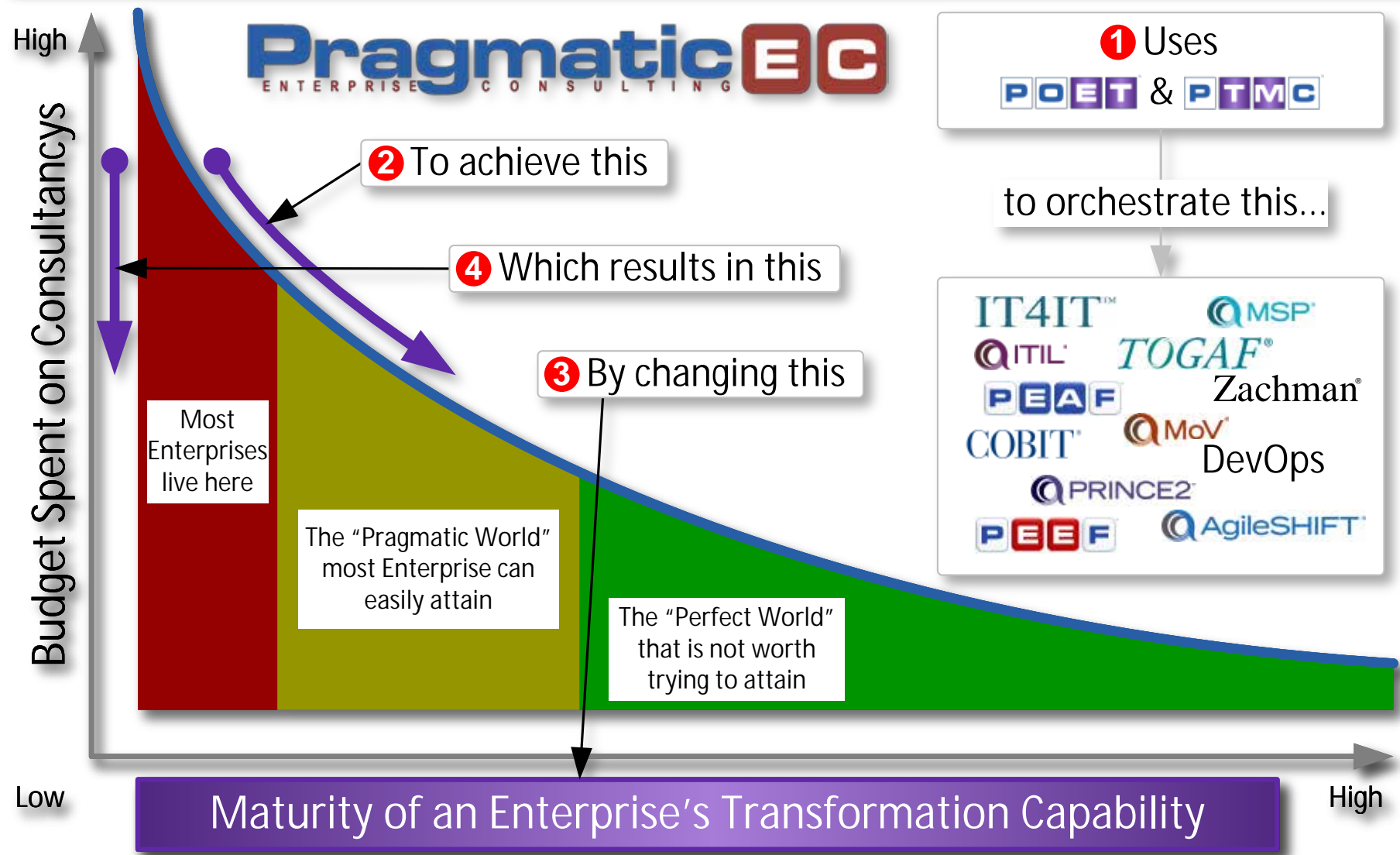

**Keypoint**  
Most consultancies only want to sell you fish.  
Pragmatic will teach you how to fish.

**Adoption**  
Management: Engage Pragmatic EC to help you reign in the budget spent on consultancies and therefore Transformation.

# What is the difference between a Pragmatic Non-Commercial License and a Pragmatic Commercial License?



- ü 350 Companies
- ü 130 Government Bodies
- ü 60 Academic Institutions
- ü 3,700 Individuals



- ü 43 Consultancies
- ü 13 Training Providers
- ü 11 Tool Vendors

**Keypoint**  
Use Pragmatic Frameworks (for free) to improve your Enterprise.

**Adoption**  
Management: Apply for a Pragmatic Commercial or Non-Commercial license depending on your circumstances.

As at Q1/2021

# What is covered in Fundamentals vs Foundation vs Certified Training?

Instructor led or Free Self-study



Day 1

Module 1



Day 2

Module 2



Day 3

Module 3

**Keypoint**  
PEAF Certified training, provides everything to enable you to adopt PEAFF.

**Adoption Management:** Engage Pragmatic EC to deliver PEAFF Certified Transformation Best Practice training.

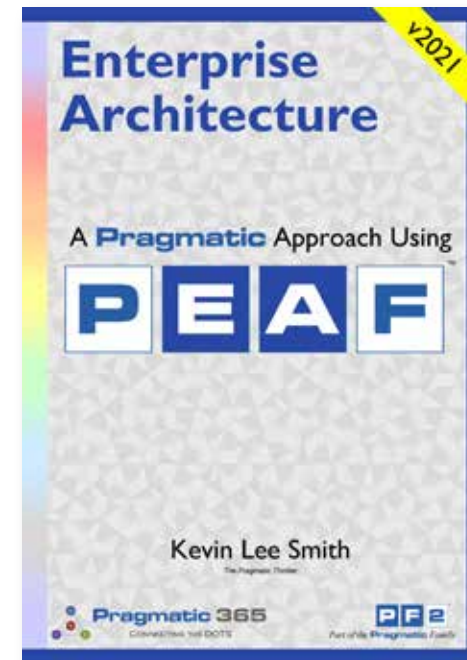
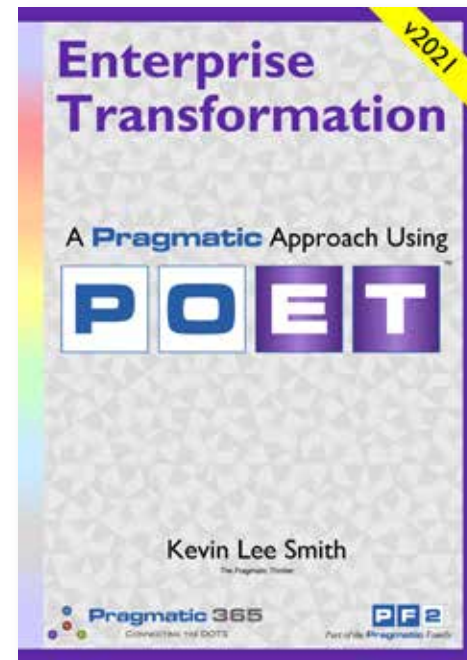
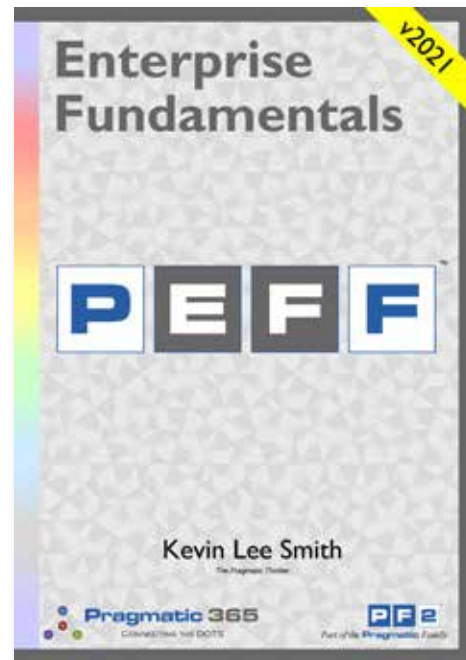
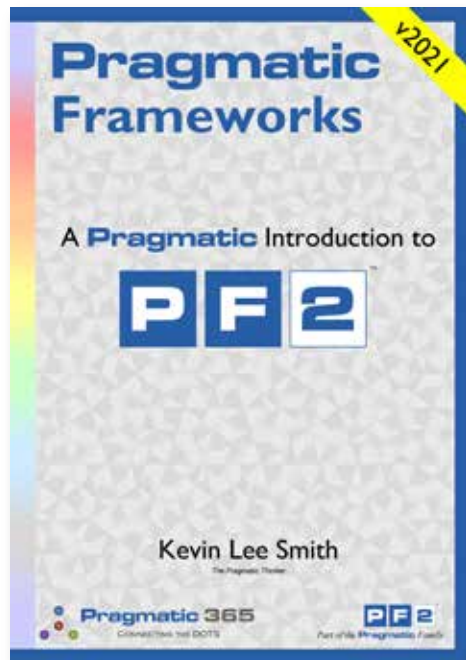



# What is covered in Pragmatic Focus Workshops?

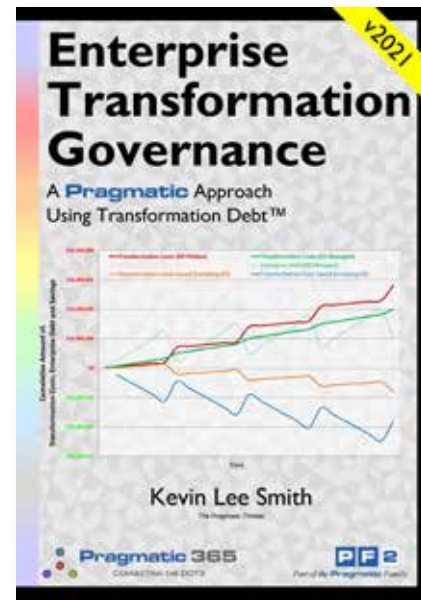
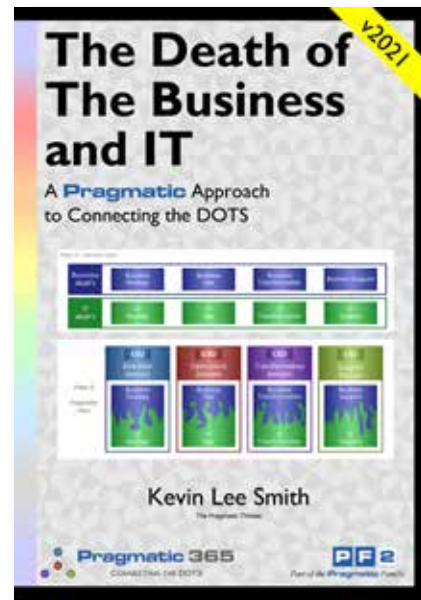
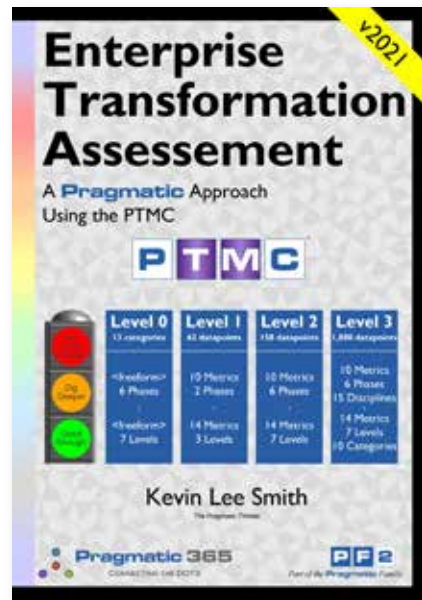
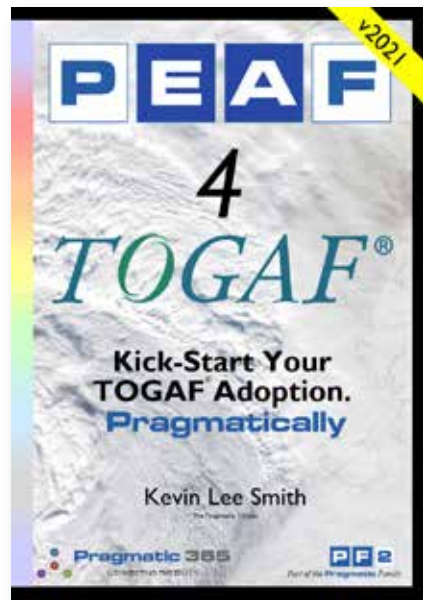

**Keypoint**  
PEAF Focused Workshops, allow you to focus on specific areas.

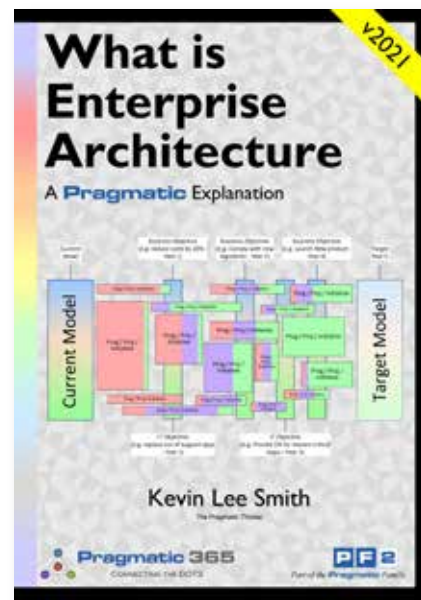
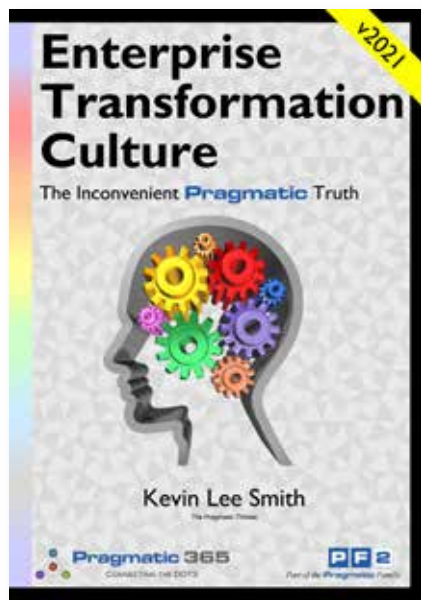

**Adoption Management:**  
Engage Pragmatic EC to deliver Focussed training.

# How do you get access to the Pragmatic Publishing Platform?

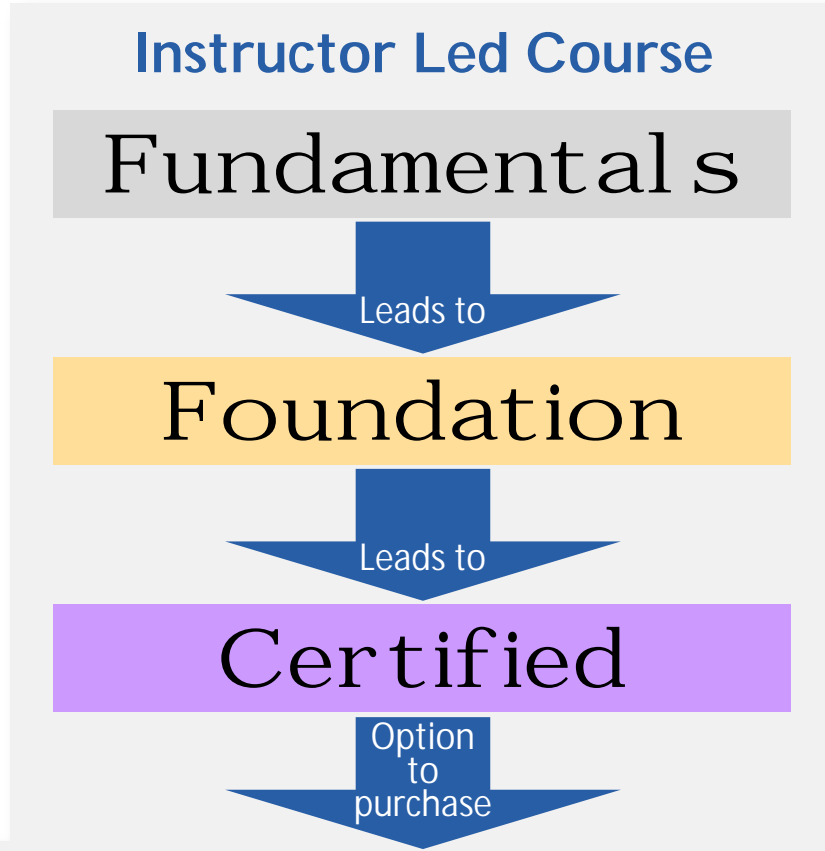

**Keypoint**  
Access to the Pragmatic Publishing Platform is granted by graduating from an Instructor led course.

**Adoption**  
EA Project Team:  
Attend Instructor led training, to gain access to the Publishing Platform and all component files.files.





# What is the Pragmatic Publishing Platform and what does it do?

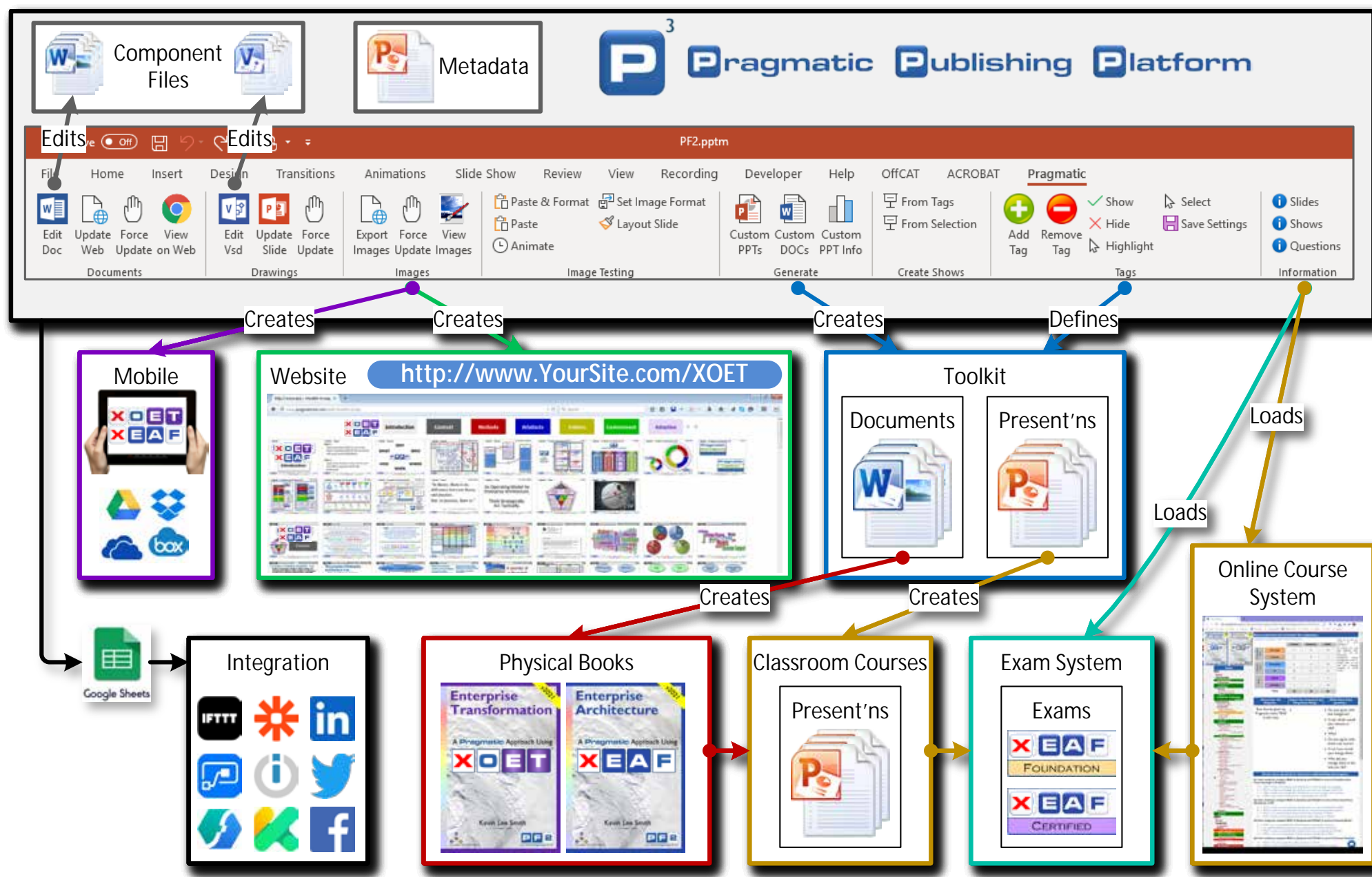

**Keypoint**  
 P3 allows Enterprises to easily produce and maintain their own Frameworks and publish them to books, their intranet and mobile devices.

**Adoption Management:** Adopt the Pragmatic Publishing Platform to streamline your Pragmatic X- Framework adoption.

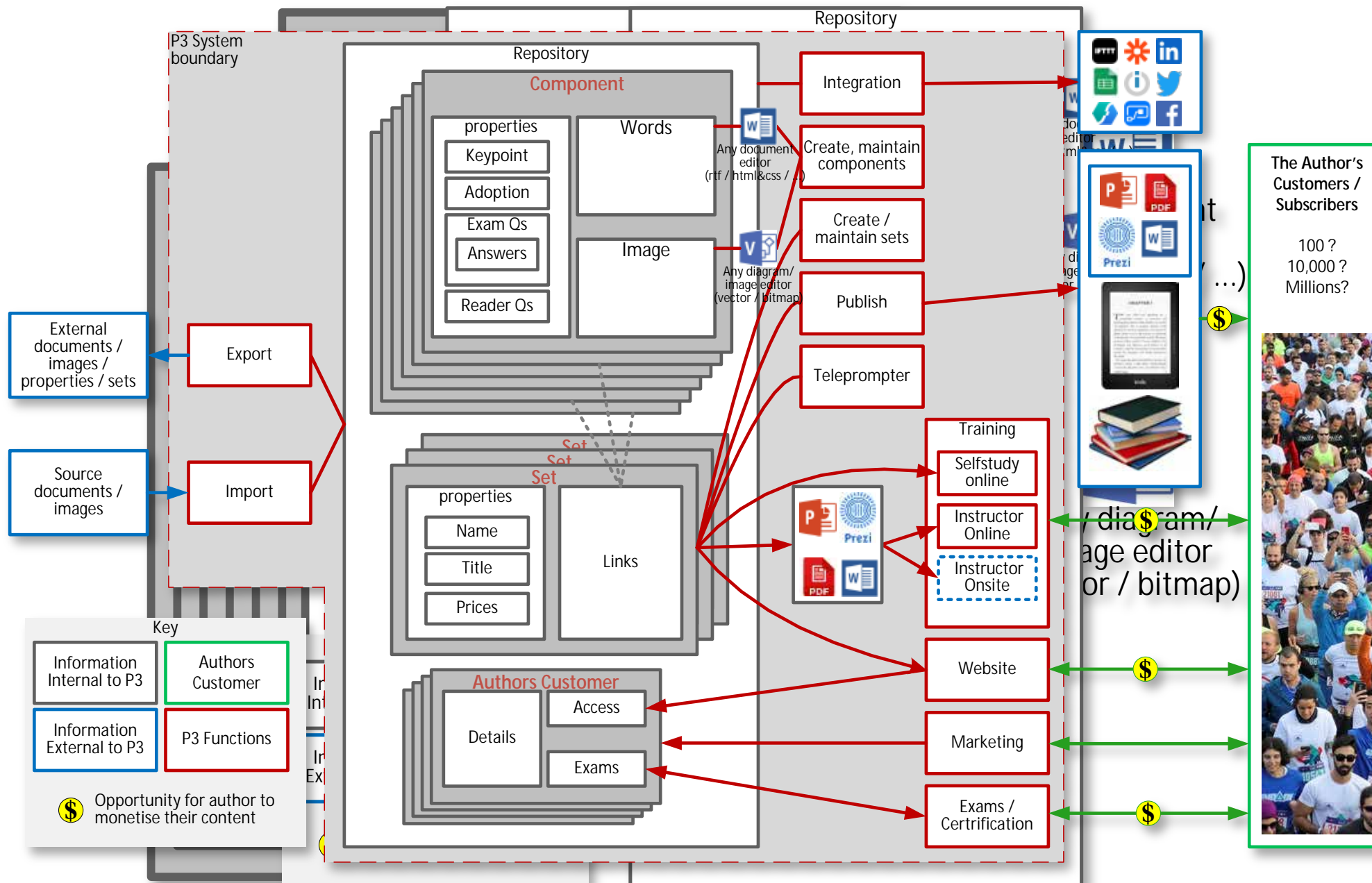

**Keypoint**  
 P3 is a  
 component  
 based authoring  
 system.

**Adoption**  
 Management: Adopt  
 the Pragmatic  
 Publishing Platform to  
 streamline your  
 Pragmatic X-  
 Framework adoption.

# What does the Frameworks section of PF2 contain?

# Frameworks

**Keypoint**  
The Frameworks section of PF2 introduces the Frameworks that are part of the Pragmatic Family.





Rather than viewing the content of POET as a sequential book, what is a better way of thinking of it?

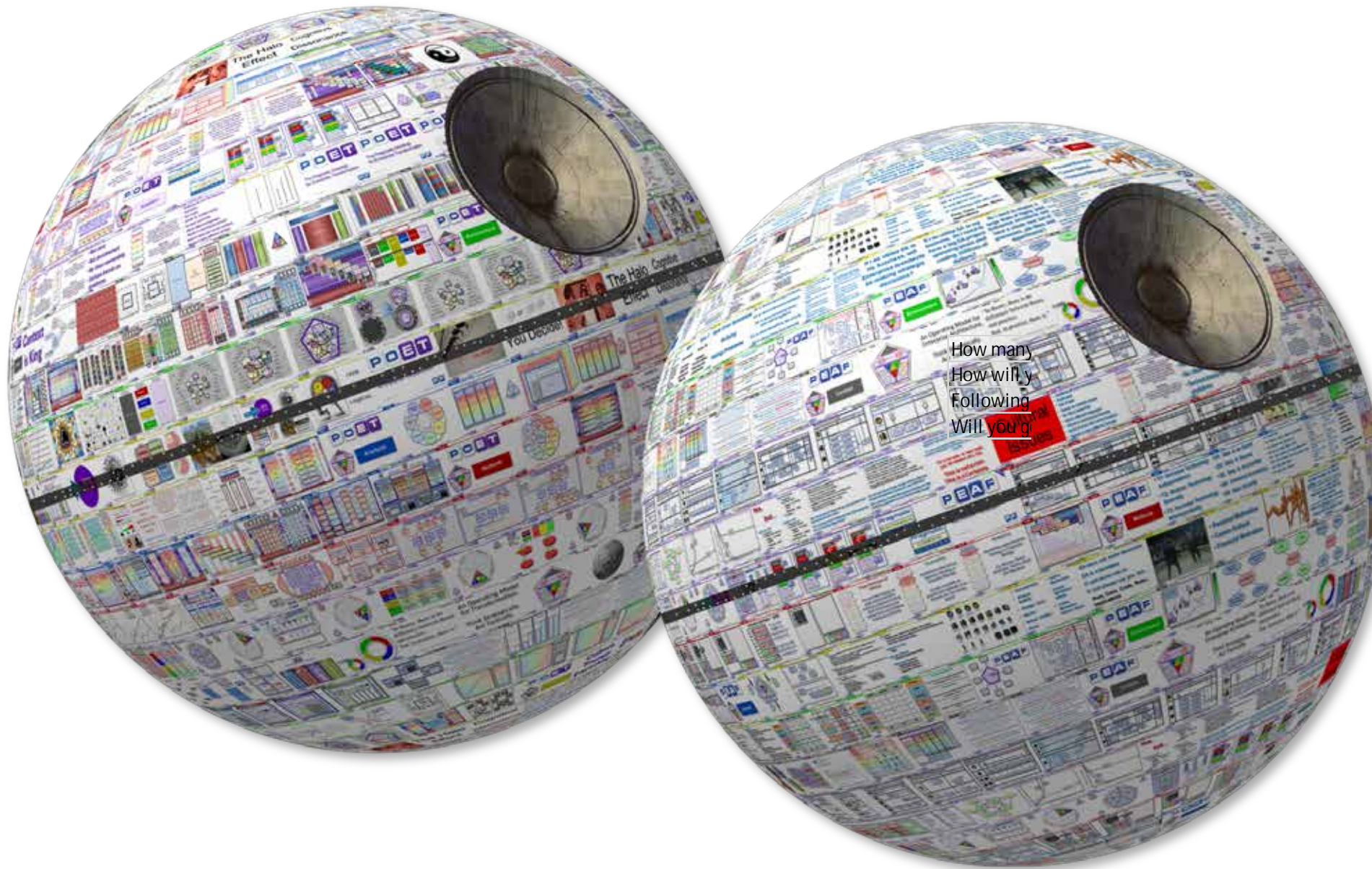

## Keypoint

To understand the whole, you first must understand the whole.

## Adoption

EA Project Team:  
Repeat training and reading to fully understand the Frameworks and how to adopt them.

# What are the Pragmatic Family of Frameworks all about?



# Connecting the DOTS

**Keypoint**  
The Pragmatic Family of Frameworks are all about Connecting the DOTS™.



# What frameworks are part of the Pragmatic Family of Frameworks?



## The Pragmatic Family of Frameworks

Enterprise



Direction



Operation



Transformation



Enterprise Architecture



Enterprise Engineering



Support



**Keypoint Pragmatic Frameworks are Pragmatic, Well-defined, Complete, Interlocking, Inheritable and Extensible.**

# What are X-Frameworks?

**Keypoint**  
Pragmatic Frameworks were designed to be modified.

**Adoption**  
EA Project Team: Modify POET and PEAFF as necessary (0-10%) to produce the Enterprise specific XOET and xEAF.

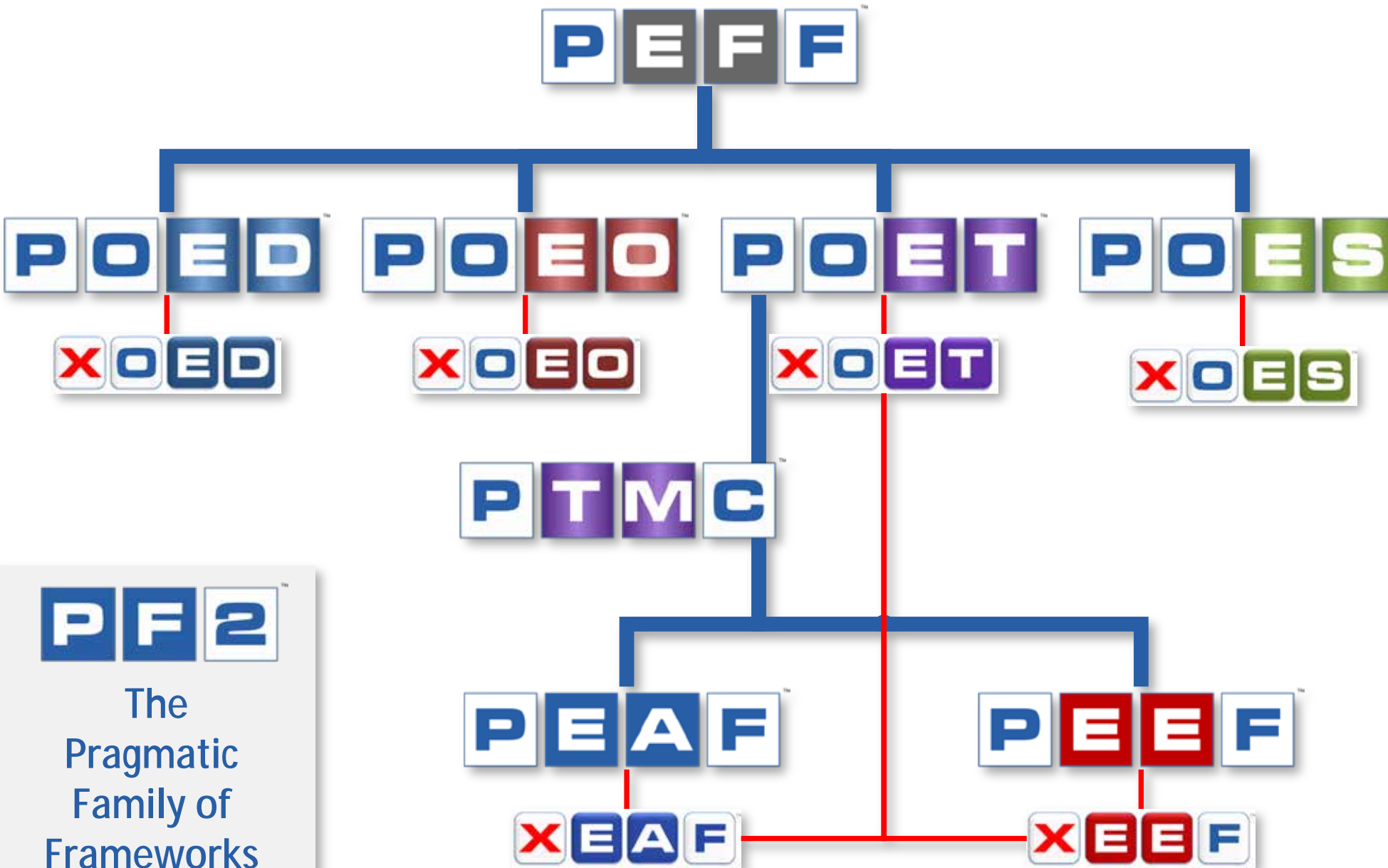

The Pragmatic Family of Frameworks



# What domains of the Enterprise, is PEAFF Applicable to?



## The Pragmatic Family of Frameworks

Applicable to the whole Enterprise	Applicable to the Enterprise's Transformation Capability	Applicable to the Enterprise's Enterprise Architecture Capability	Applicable to the Enterprise's Enterprise Engineering Capability
PEFF	PEFF	PEFF	PEFF
	POET	POET	POET
		PEAF	PEEF

**Keypoint**  
 PEAFF inherits from POET  
 inherits from PF2.

**Adoption**  
 All: First Study PF2. Second Study POET.  
 Third study PEAFF.

# Which 3 frameworks currently exist and how are they related?

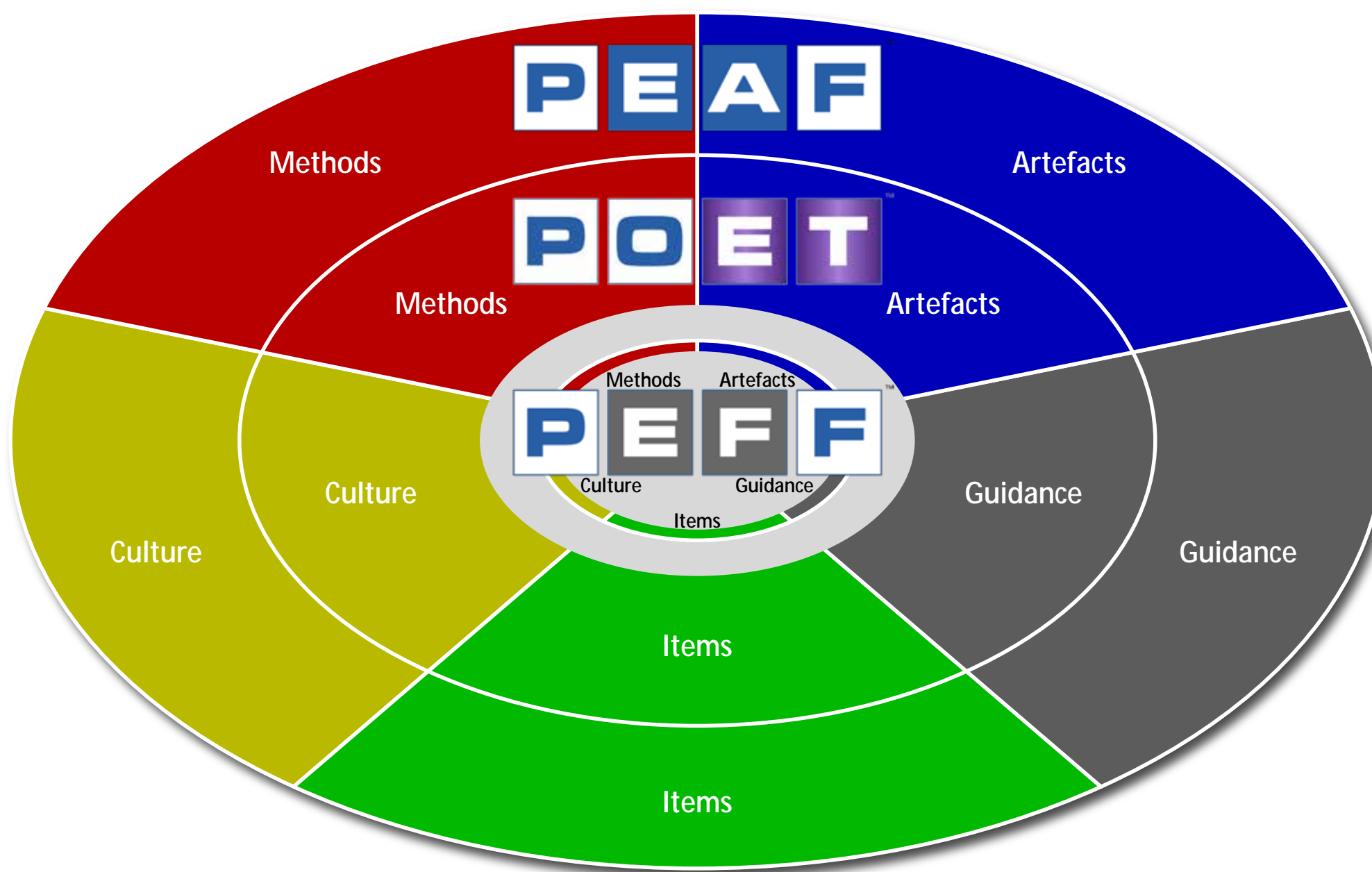

**Keypoint**  
 PEFF provides the Context for POET  
 provides the Context for PEAFF.

**Adoption**  
 EA Project Team:  
 Make sure you adopt all the frameworks that a framework inherits from.

# What two things mostly influenced POET and PEAFF?

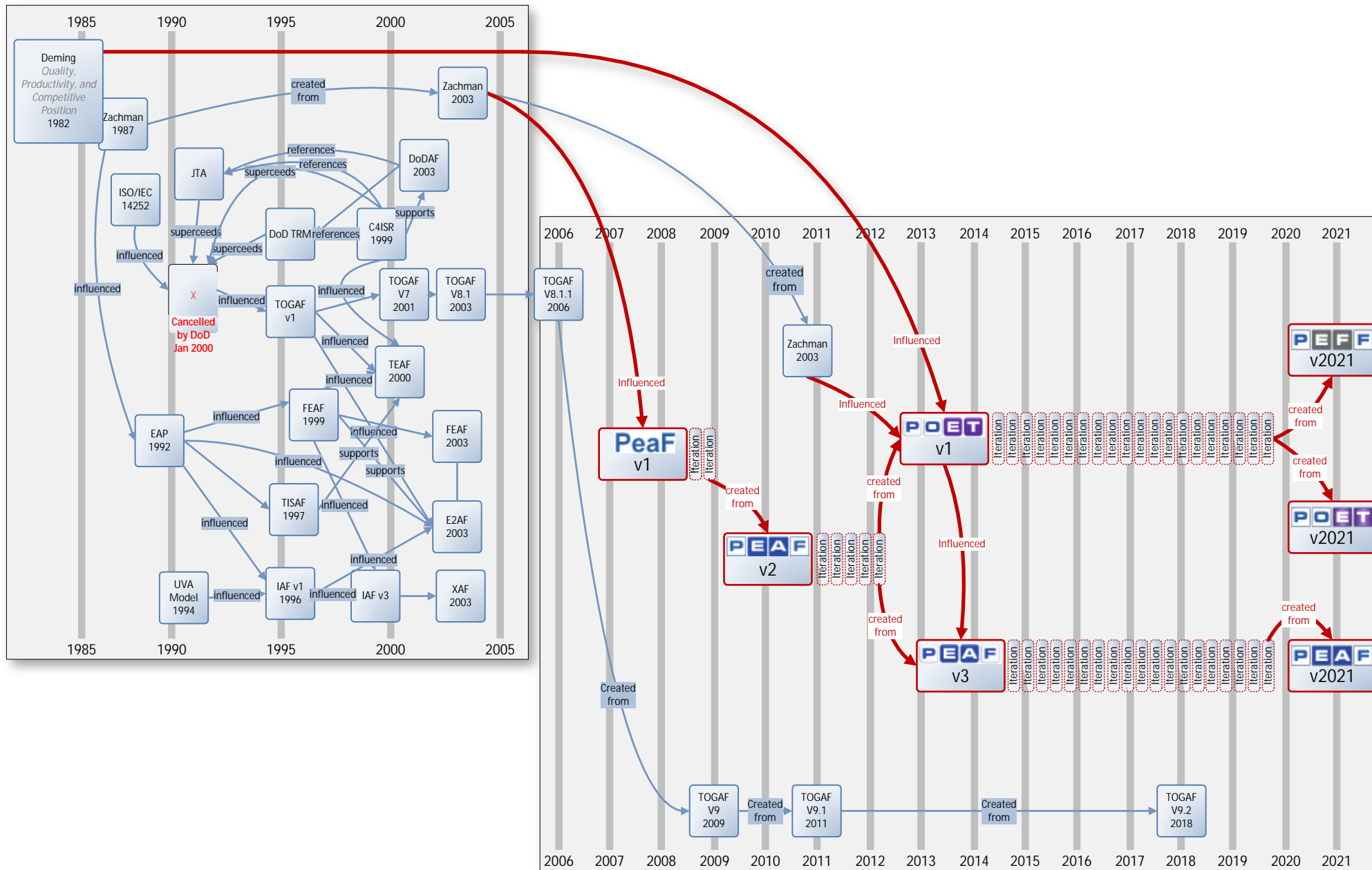

**Keypoint**  
**Pragmatic**  
**Frameworks**  
 were mostly  
 influenced by  
 the thinking of  
 Deming and  
 Zachman.

# How did POET grow out of PEAFF?

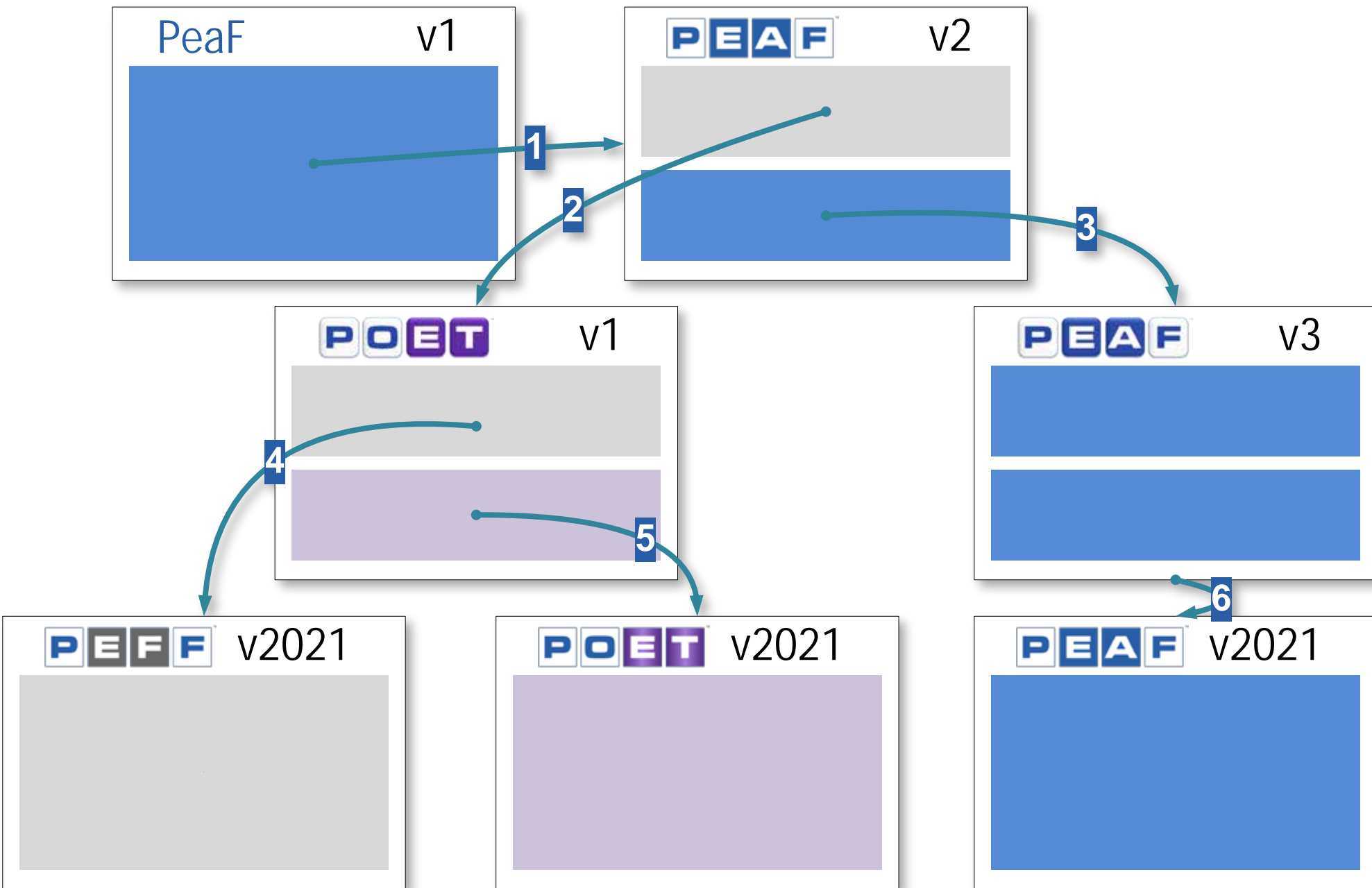

**Keypoint**  
 POET grew out of things originally in PEAFF, that applied to all of the Transformation space, not just the EA part.



# What does PEFF stand for?



## Enterprise Fundamentals

**Keypoint**  
PEFF - The  
Pragmatic  
Enterprise  
Fundamentals  
Framework.

**Adoption**  
C-Suite: Instigate a  
review of the Enterprise's  
EA Capability, and  
determine if PEFF can be  
useful to the Enterprise.



# What does PEFF allow Executive Management to do?

**PEFF** allows Executive Management to take a coherent and holistic **view** of their **Whole Enterprise,**

by providing **fundamental structures,** to enable **informed decision making,**

allowing them to pragmatically increase its **Effectiveness and Efficiency.**

## Keypoint

PEEF allows an Enterprise to define and put in place fundamental Ontologies used throughout an Enterprise.

## Adoption

Management: Use PEFF to instill a set of fundamental strategically important Ontologies into the Enterprise.

# What does POET stand for?



# Enterprise Transformation

**Keypoint**  
POET - The  
Pragmatic  
Operating model for  
Enterprise  
Transformation.

**Adoption**  
C-Suite: Instigate a  
review of the Enterprise's  
Transformation Capability,  
and determine if POET  
can be useful to the  
Enterprise.



# How should you use POET?

Transformation Operating Model

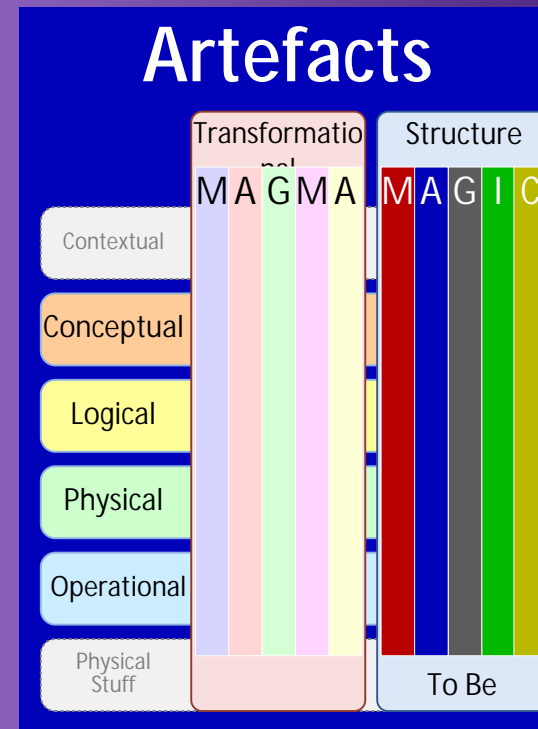
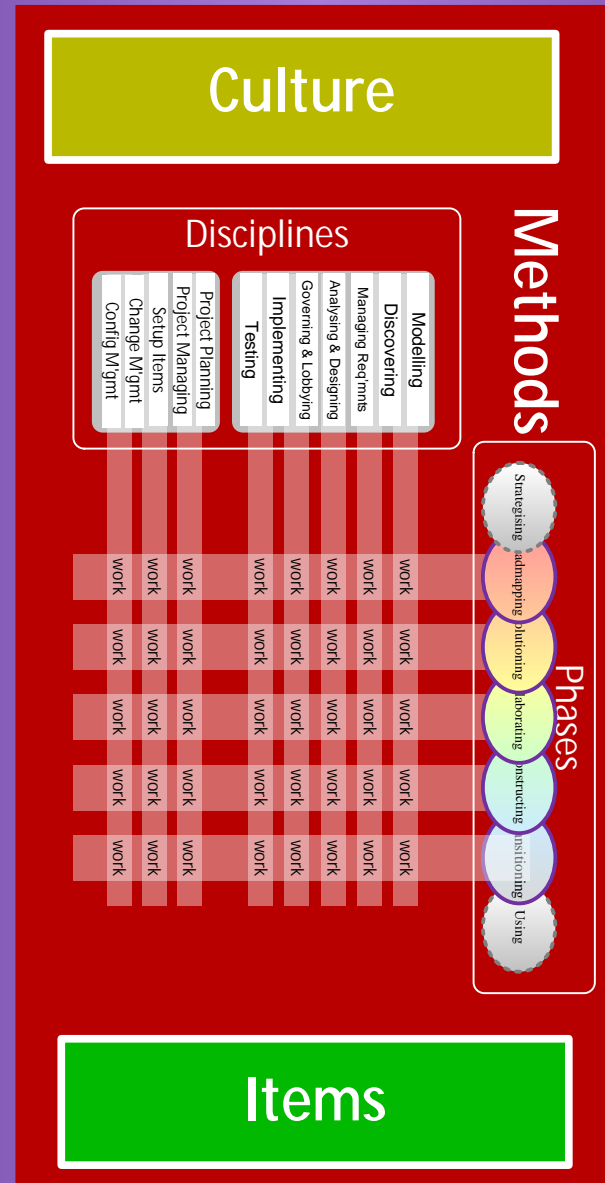
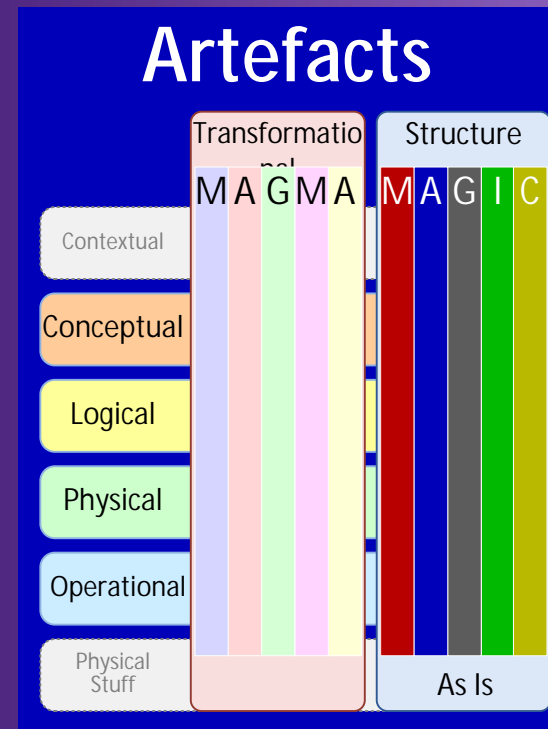

**Keypoint**  
 POET allows you to Strategically guide the Tactical changes, to the Transformation capability of your Enterprise.

**Adoption**  
 C-Suite: Mandate the use of POET to Strategically guide, Tactical changes to the Transformation capability of your Enterprise.

# How does POET help?

**POET** allows Executive Management to take a coherent and holistic **view** of their **Transformation Capability**,

by providing a coherent & holistic **MAGIC Framework**, to enable **informed decision making**,

allowing them to pragmatically increase its **Effectiveness and Efficiency**.

## Keypoint

POET allows an Enterprise to take a coherent and holistic view of the Transformation part of your Enterprise.

## Adoption

Management: Use POET to take a coherent and holistic view of the Transformation part of your Enterprise.





# How should POET be used?

## An Operating Model for Transformation

which allows you to...

# Think Strategically

which allows you to...

# Act Tactically

### Keypoint

POET allows an Enterprise to Tactically improve parts of Transformation, in the context of the Strategic whole.

### Adoption

Management: Use POET to enable Tactically improve parts of Transformation, in the context of the Strategic whole.

# What does PEAFF stand for?



## Enterprise Architecture

**Keypoint**  
PEAFF - The  
Pragmatic  
Enterprise  
Architecture  
Framework.

**Adoption**  
C-Suite: Instigate a  
review of the Enterprise's  
EA Capability, and  
determine if PEAFF can be  
useful to the Enterprise.







# How does PEAFF help?

**PEAFF** allows Executive Management to take a coherent and holistic **view** of their **Enterprise Architecture Capability,**

by providing a coherent & holistic **MAGIC Framework,** to enable **informed decision making,**

allowing them to pragmatically increase its **Effectiveness and Efficiency.**

## Keypoint

PEAFF allows an Enterprise to take a coherent and holistic view of the Strategising and Roadmapping (EA) Transformation phases of your Enterprise.

## Adoption

Management: Use PEAFF to take a coherent and holistic view of the Transformation part of your Enterprise.



# How should PEAf be used?



## A Logical Model for Enterprise Architecture.

which allows you to...

# Think Strategically

which allows you to...

# Act Tactically

### Keypoint

PEAF allows an Enterprise to Tactically improve parts of EA, in the context of the Strategic whole.

### Adoption

Management: Use PEAf to enable Tactically improve parts of Transformation, in the context of the Strategic whole.

# What does PTMC stand for?



# Transformation Maturity

**Keypoint**  
PTMC - The  
Pragmatic  
Transformation  
Maturity Canvas.

**Adoption**  
Management: Use the  
PTMC to pragmatically  
expose the good the  
bad and the ugly with  
respect to your  
Transformation domain.

# How does the PTMC help?

**PTMC** allows Executive Management to **assess** the fitness of their **Transformation Capability,**

by providing a coherent & holistic **MAGIC Framework,** to enable **informed decision making,**

allowing them to pragmatically decide which parts to **tactically adjust.**

## Keypoint

PTMC allows an Enterprise to assess the fitness of the Transformation Capability of your Enterprise.

## Adoption

Management: Use the PTMC to assess the fitness of the Transformation Capability of your Enterprise.



# How should the PTMC be used?



An Assessment Tool for  
Enterprise Transformation.

which allows you to...

**Think Strategically**

which allows you to...

**Act Tactically**

## Keypoint

The PTMC allows an Enterprise to Strategically assess its Transformation Capability, so it can Tactically mature it.

## Adoption

Management: Use the PTMC to Strategically assess its Transformation Capability.

# How should you use the PTMC?

## Transformation Maturity

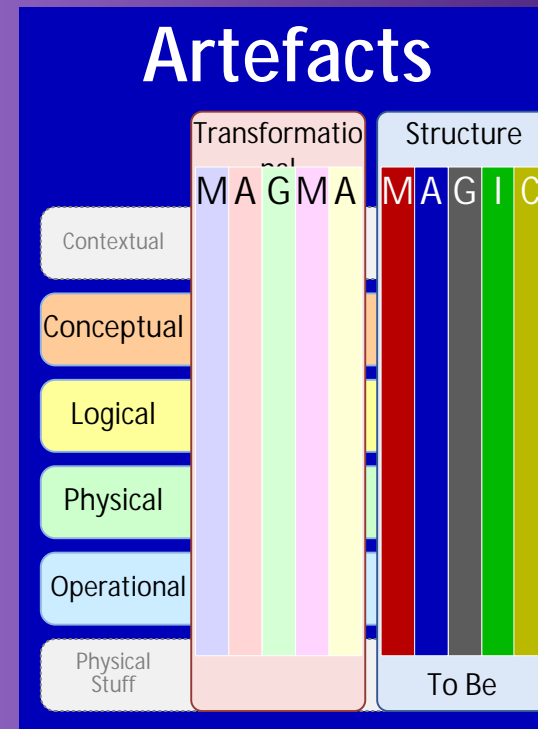
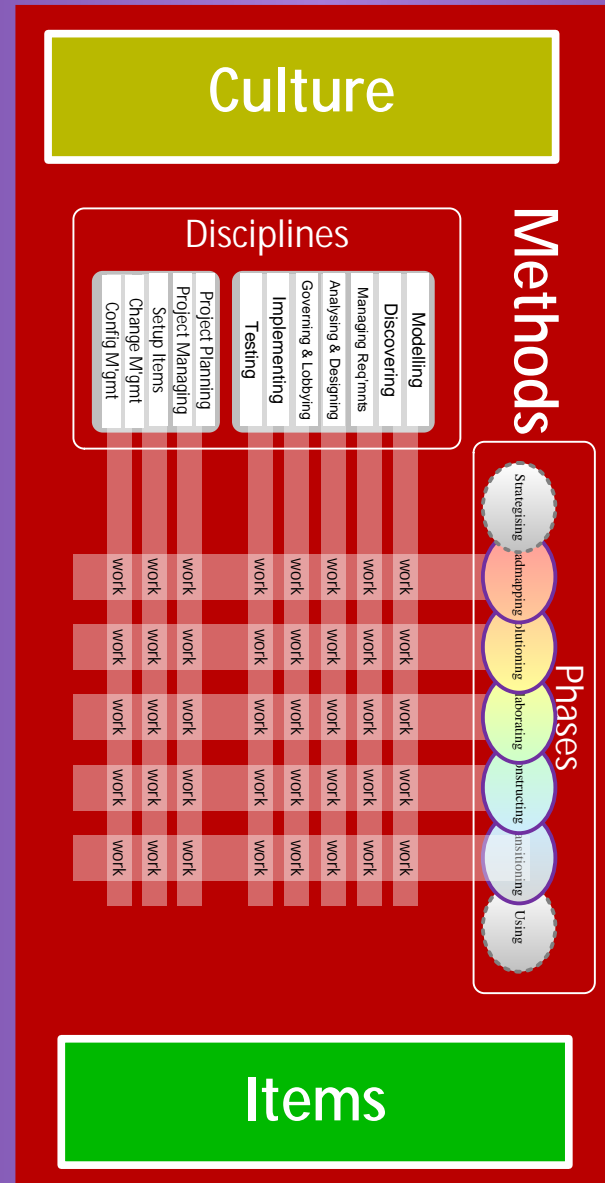
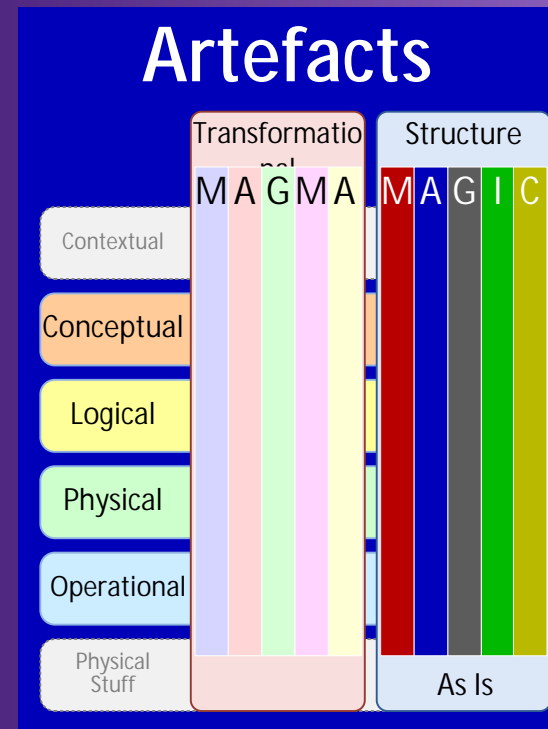

**Keypoint**  
The PTMC allows you to Pragmatically assess the Transformation capability of your Enterprise.

**Adoption**  
C-Suite: Mandate the use of PTMC to assess the Transformation capability of your Enterprise.



# What does POED stand for?



## Enterprise Direction

**Keypoint**  
POED - The  
Pragmatic  
Operating model for  
Enterprise Direction.

**Adoption**  
C-Suite: Instigate a  
review of the Enterprises  
Direction capability, and  
determine if POED can  
be useful to the  
Enterprise.



# How should you use POED?

Direction Operating Model

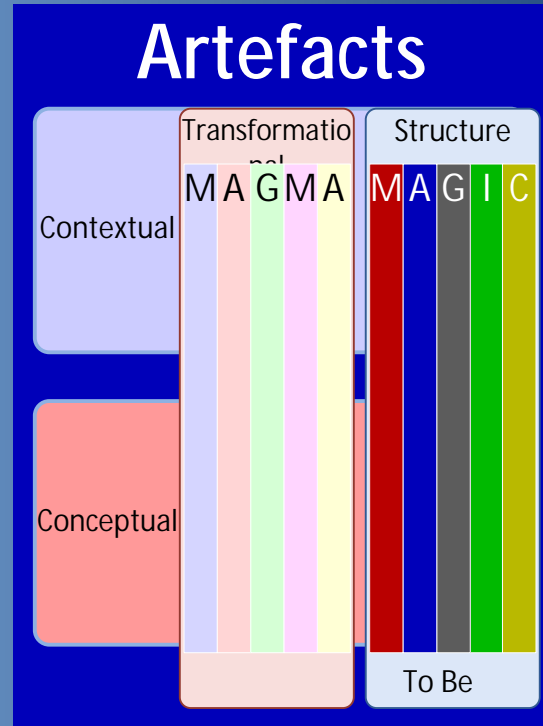
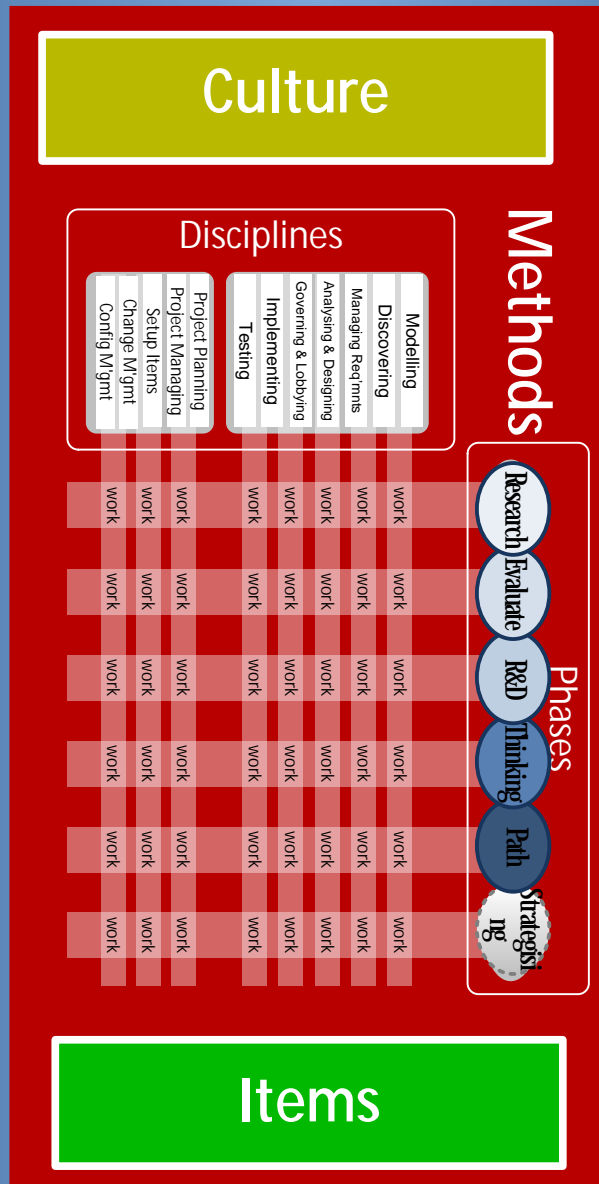
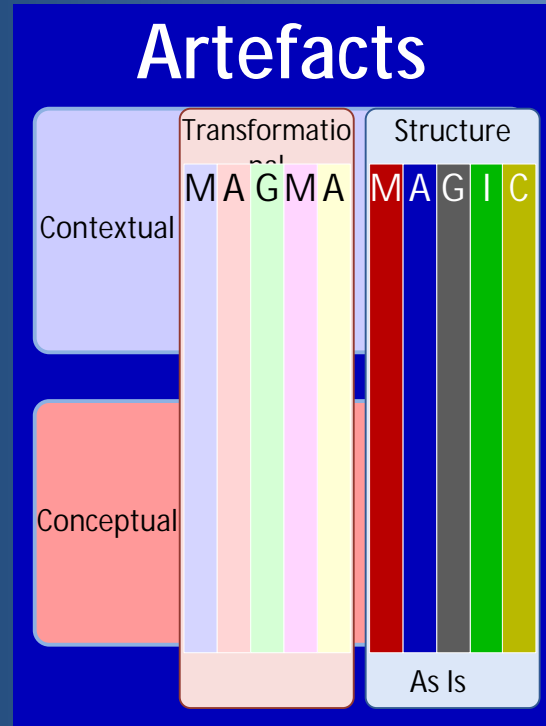

**Keypoint**  
POED allows you to Strategically guide the Tactical changes, to the Direction capability of your Enterprise.

**Adoption**  
C-Suite: Mandate the use of POED to Strategically guide, Tactical changes to the Direction capability of your Enterprise.



# What does POEO stand for?



# Enterprise Operation

**Keypoint**  
POEO - The  
Pragmatic  
Operating model for  
Enterprise  
Operation.

**Adoption**  
C-Suite: Instigate a  
review of the Enterprises  
Operation capability, and  
determine if POEO can  
be useful to the  
Enterprise.

**BREAK!**

Back at **10:43**



# How should you use POEO?

Operation  
Operating  
Model

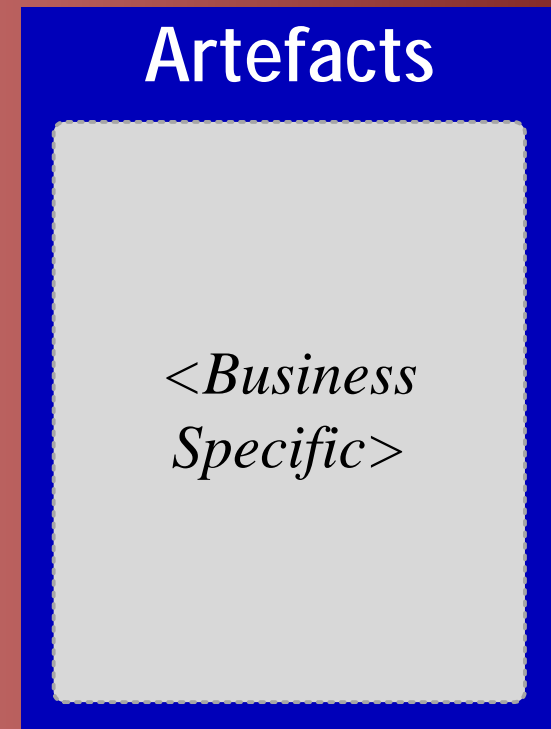
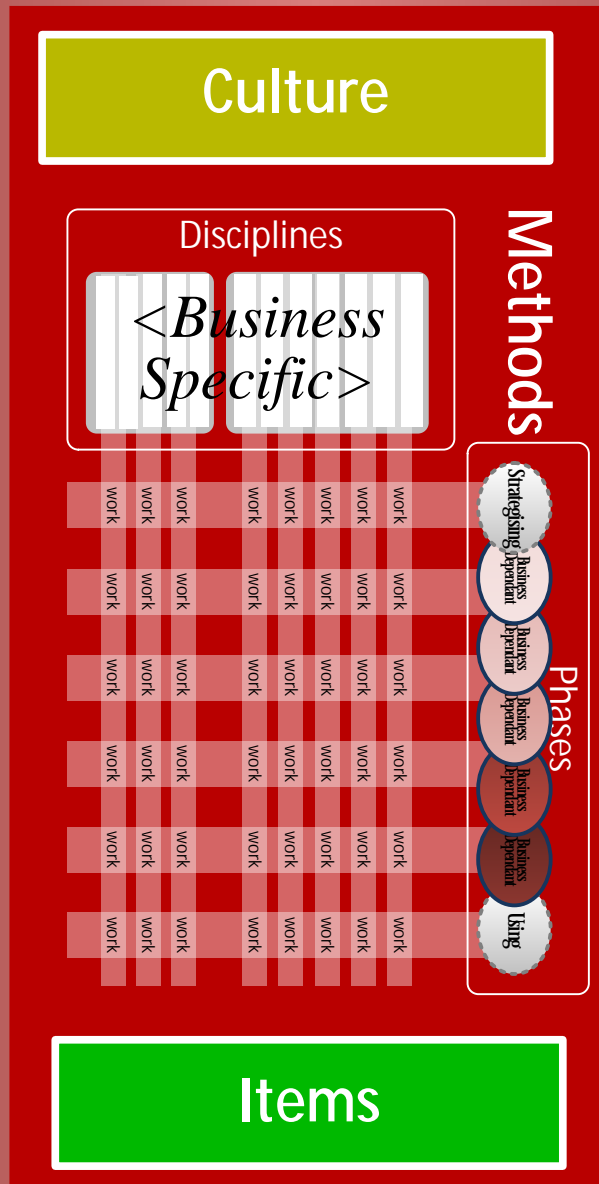

**Keypoint**  
POEO allows you to Strategically guide the Tactical changes, to the Operation capability of your Enterprise.

**Adoption**  
C-Suite: Mandate the use of POEO to Strategically guide, Tactical changes to the Operation capability of your Enterprise.

# What does POES stand for?



# Enterprise Support

**Keypoint**  
POES - The  
Pragmatic  
Operating model for  
Enterprise Support.

**Adoption**  
C-Suite: Instigate a  
review of the Enterprises  
Support capability, and  
determine if POES can  
be useful to the  
Enterprise.

# How should you use POES?

Transformation Operating Model

### Artefacts

- Requests
- Incidents
- Problems
- Events
- Access

### Culture

Disciplines

Methods

Change Mgmt	Ops Mgmt	Monitoring	Event Mgmt	Request Mgmt	Problem Mgmt	Incident Mgmt
work	work	work	work	work	work	work
work	work	work	work	work	work	work
work	work	work	work	work	work	work
work	work	work	work	work	work	work
work	work	work	work	work	work	work
work	work	work	work	work	work	work
work	work	work	work	work	work	work
work	work	work	work	work	work	work
work	work	work	work	work	work	work

Phases

Accept Request

Triage

Understand

Resolution

Fulfillment

### Items



### Artefacts

- Requests
- Incidents
- Problems
- Events
- Access

**Keypoint**  
 POES allows you to Strategically guide the Tactical changes, to the Support capability of your Enterprise.

**Adoption**  
 C-Suite: Mandate the use of POES to Strategically guide, Tactical changes to the Support capability of your Enterprise.

# What does PEEF stand for?

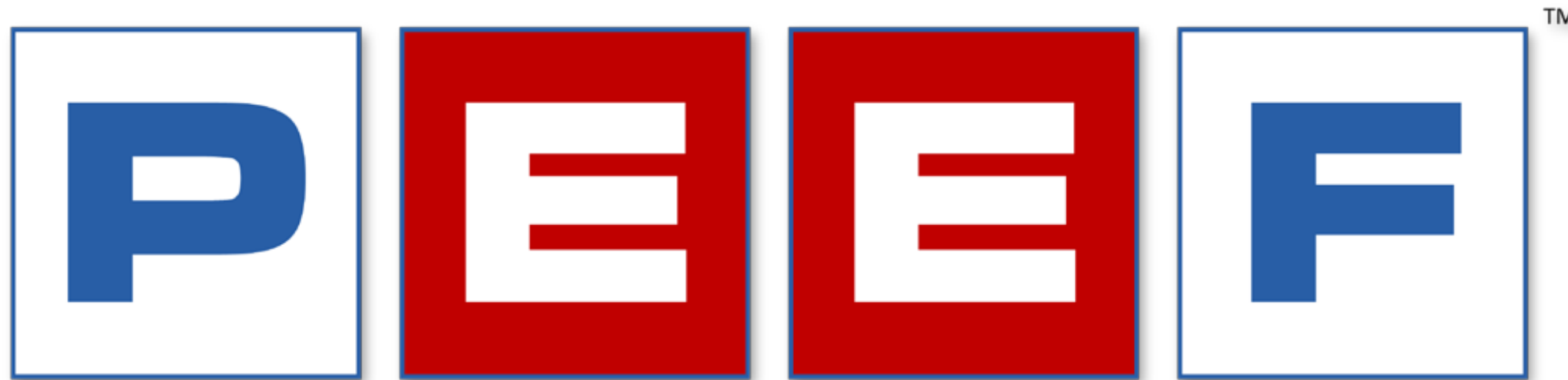

Enterprise  
Engineering

**Keypoint**  
PEEF - The  
Pragmatic  
Enterprise  
Engineering  
Framework.

**Adoption**  
C-Suite: Instigate a  
review of the Enterprise's  
Enterprise Engineering  
Capability, and determine  
if PEEF can be useful to  
the Enterprise.



# How should you use POET?

Transformation Operating Model

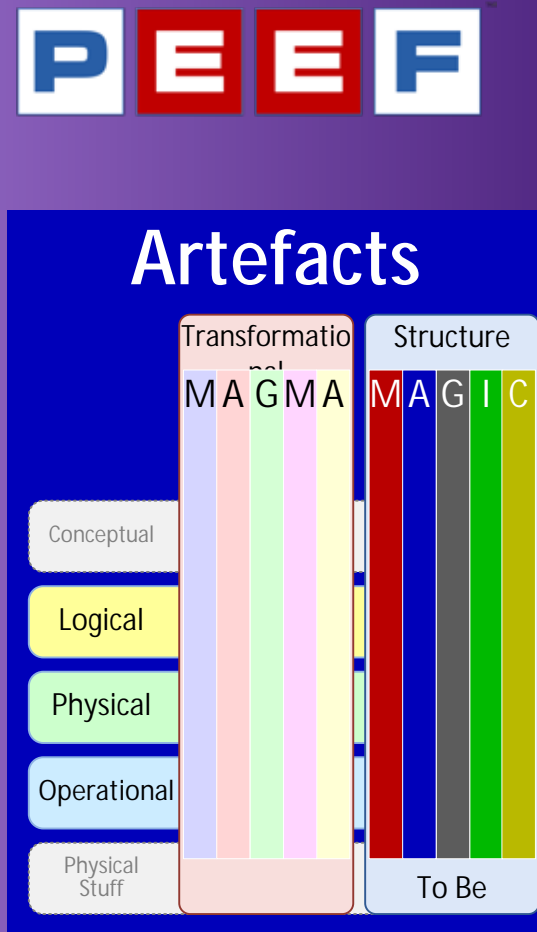
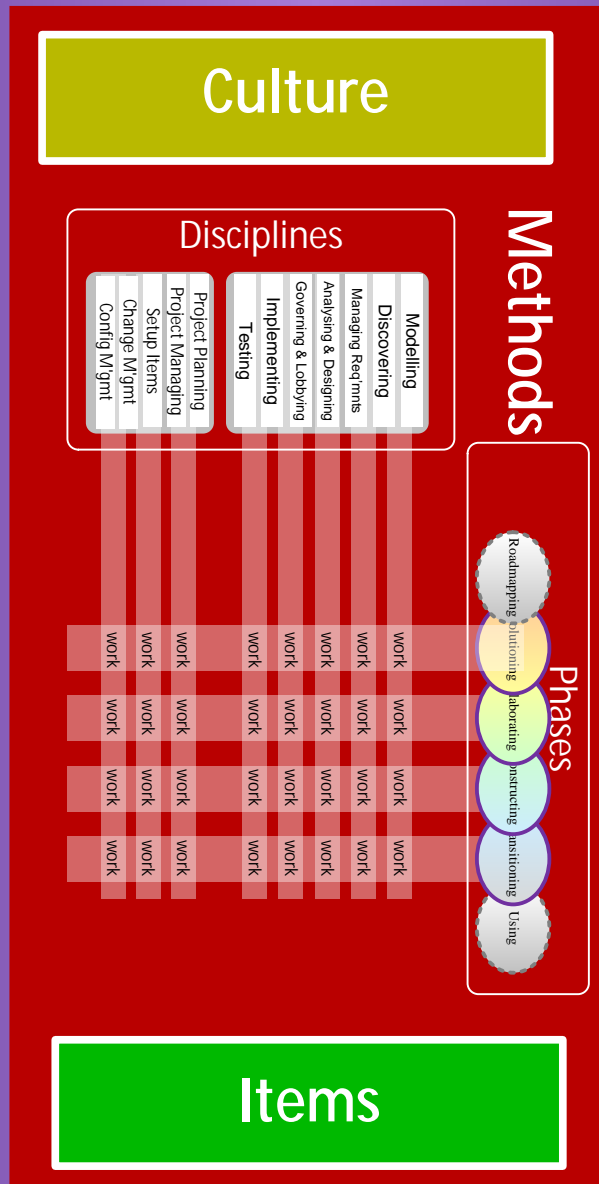
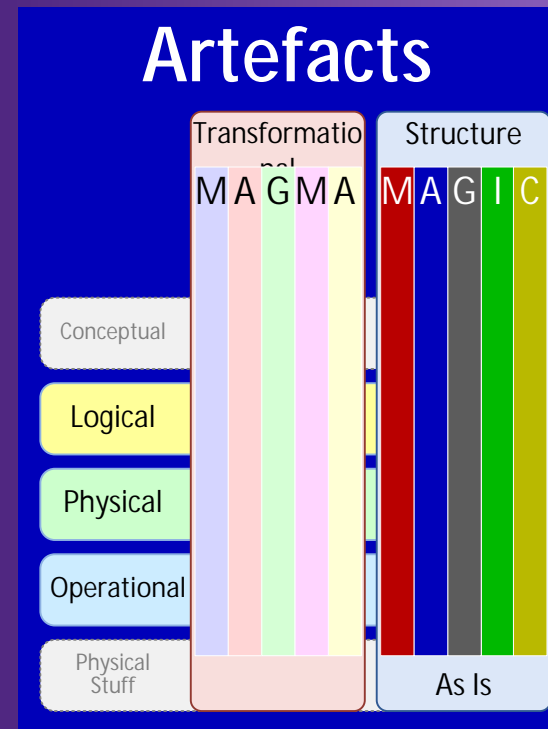

## Keypoint

POET allows you to Strategically guide the Tactical changes, to the Transformation capability of your Enterprise.

## Adoption

C-Suite: Mandate the use of POET to Strategically guide, Tactical changes to the Transformation capability of your Enterprise.

# How Theoretical or Concrete and Simple or Complex is Zachman?

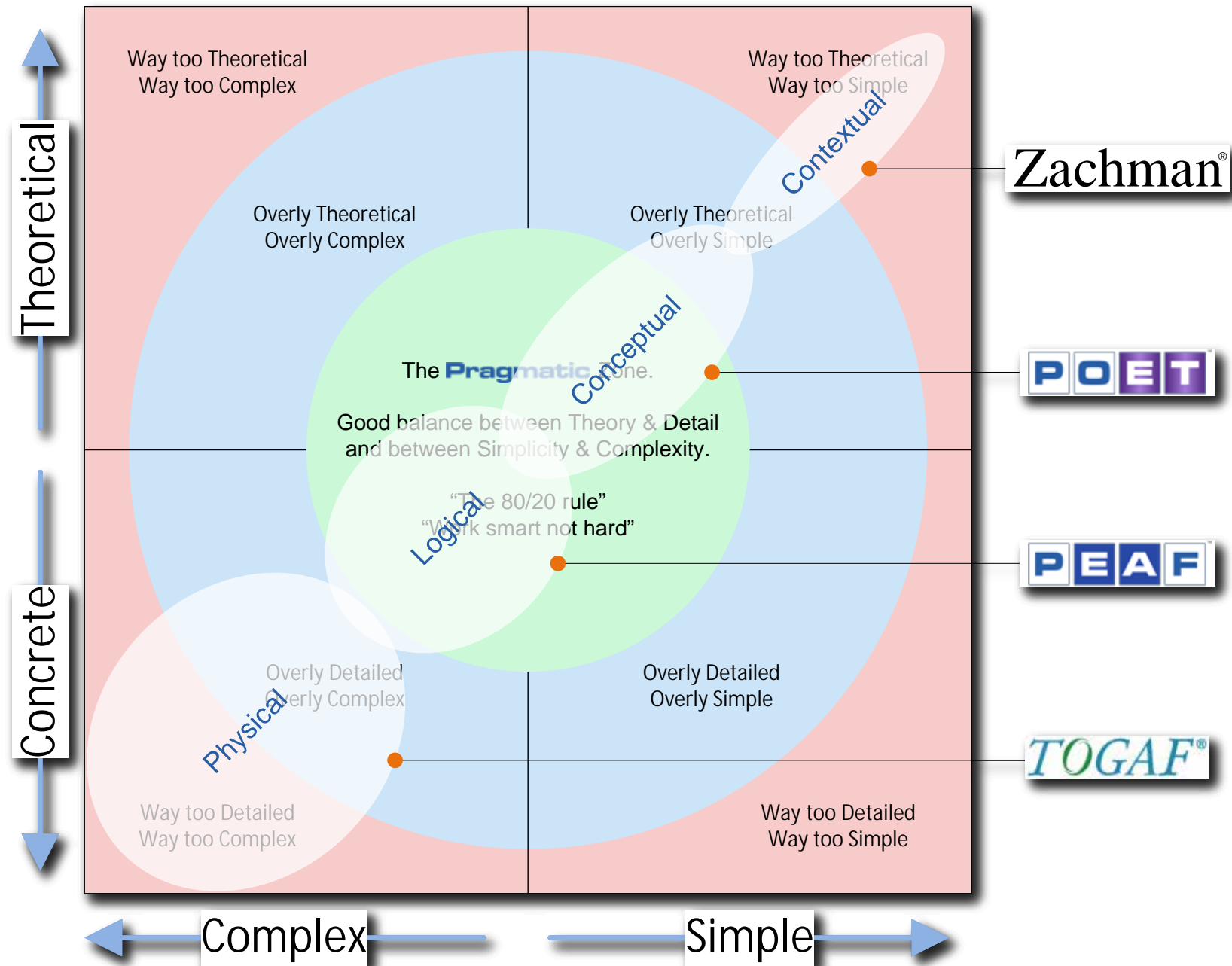

**Keypoint**  
 POET and PEAFF  
 bridge the chasm  
 between Zachman  
 and TOGAF.

**Adoption**  
 Management: Use  
 POET and PEAFF to  
 bridge the chasm  
 between Zachman  
 and TOGAF.

# What are the two common misunderstandings about POET and PEAFF?

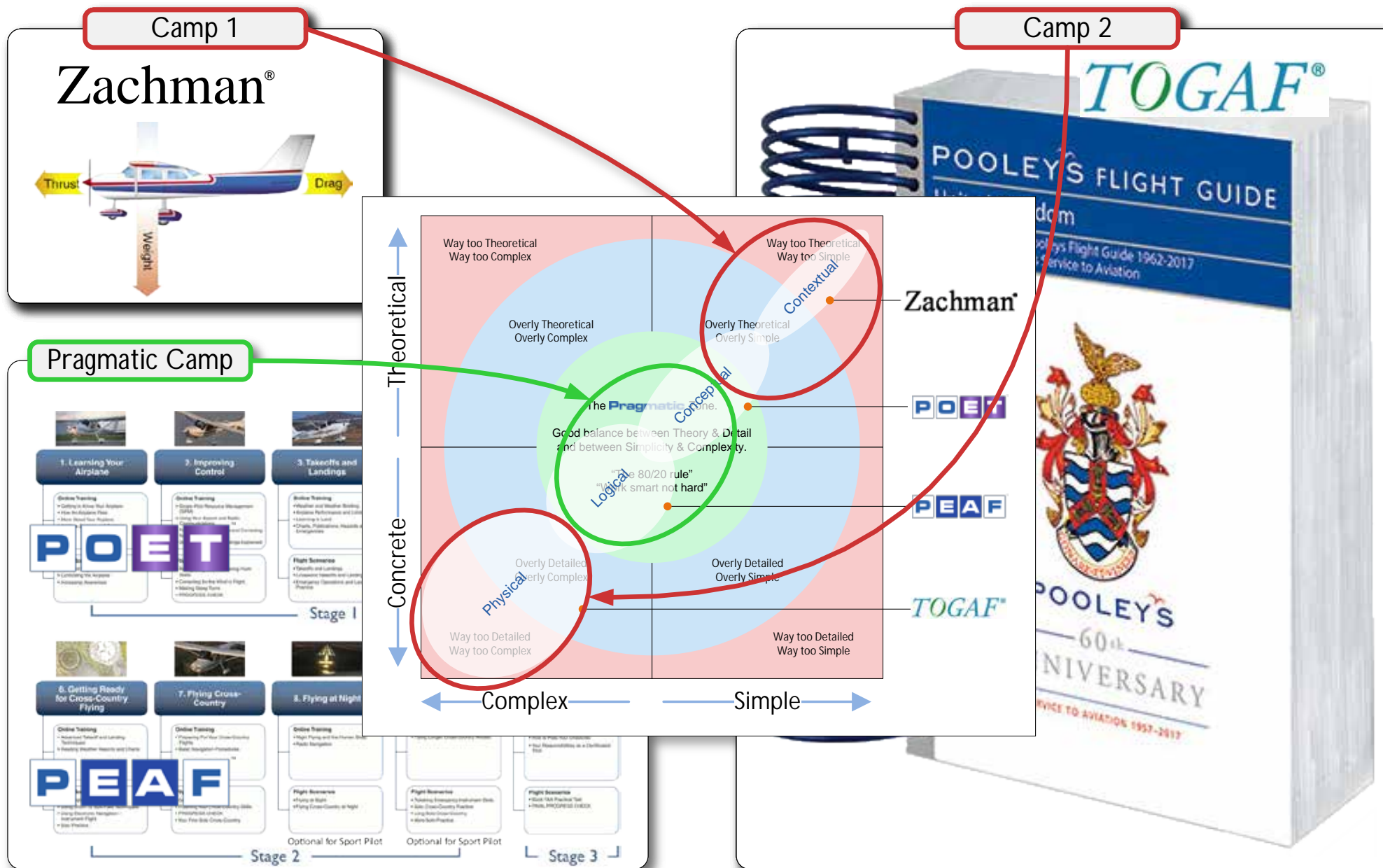

**Keypoint**  
 People incorrectly think Pragmatic Frameworks are either too high level and conceptual or incorrectly think they are too large and detailed.

**Adoption**  
 EA Project Team:  
 Use POET and PEAFF in the way they were designed to be used.

# What categories could we use to compare EA Frameworks?

Strategic	<p><b>Transformational Focus</b></p> <p>How much the framework is focussed on Strategic Planning and Roadmapping vs Project Level work.</p>
Project	
Enterprise	<p><b>Structural Focus</b></p> <p>How much the framework is focussed on the structure of the entire Enterprise vs mostly IT.</p>
IT	
Detail	<p><b>Content</b></p> <p>An indication of how detailed the framework is vs how usable it is.</p>
Usability	

**Keypoint**  
**Key Framework comparison criteria:**  
**Strategic vs Project,**  
**Enterprise vs IT, Detail vs Usability.**



# How would you compare PEAFF to Zachman and TOGAF in terms of Transformation Focus (Strategic vs Project)?

		TOGAF	Zachman	PEAF
Transformation Focus	Strategic	2	8	10
	Project	5	8	2
Structural Focus	Enterprise	2	2	10
	IT	10	10	10
Content	Detail	8	1	4
	Usability	1	1	10
Total		28	30	46

**Keypoint Raw Scores given by Pragmatic show PEAFF in the lead.**



# Which Framework should you choose?

Transformation Focus

Structural Focus

Content

TOGAF

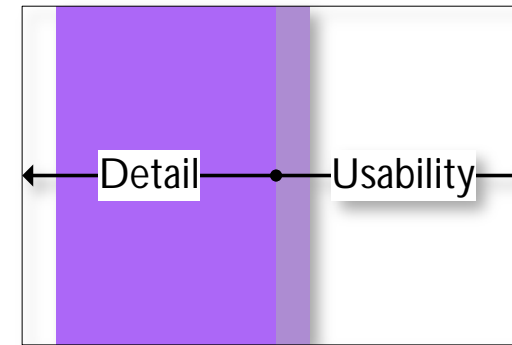
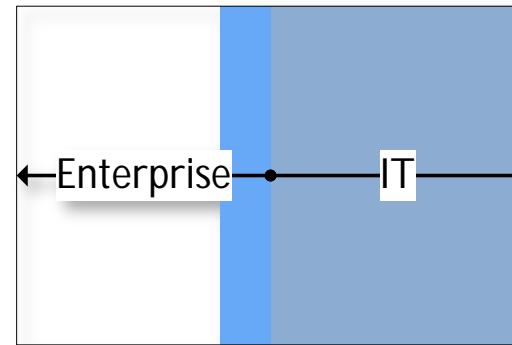
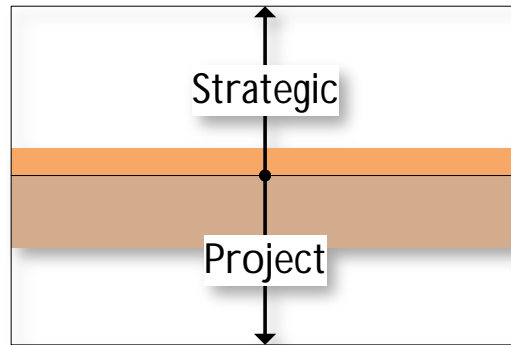

Zachman

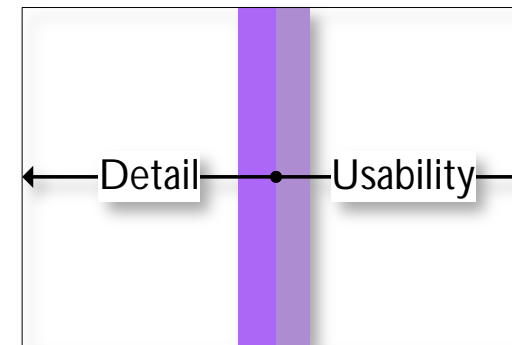
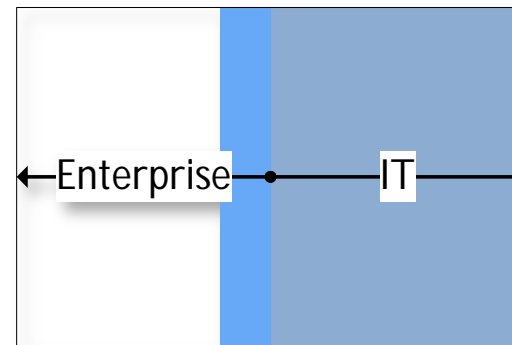
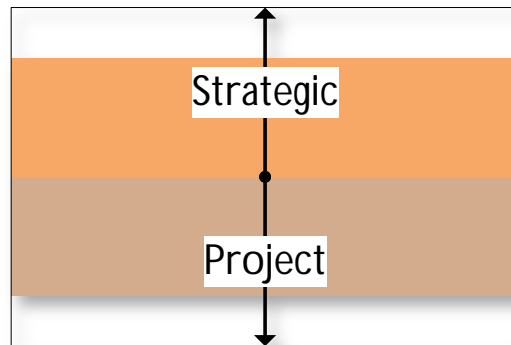

PEAF

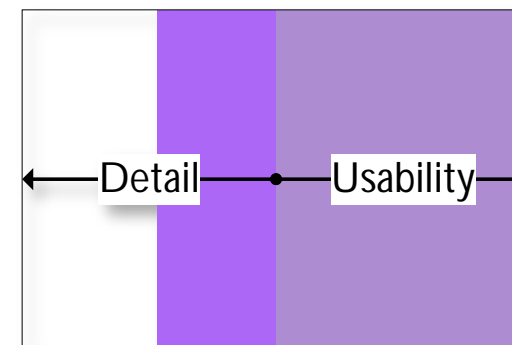
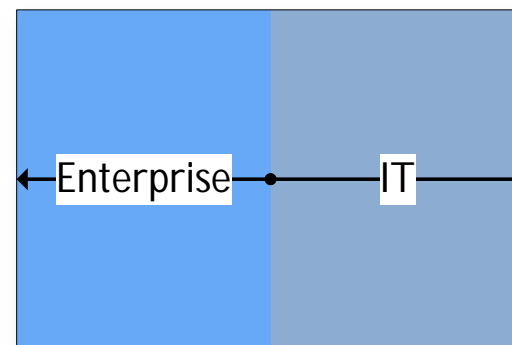
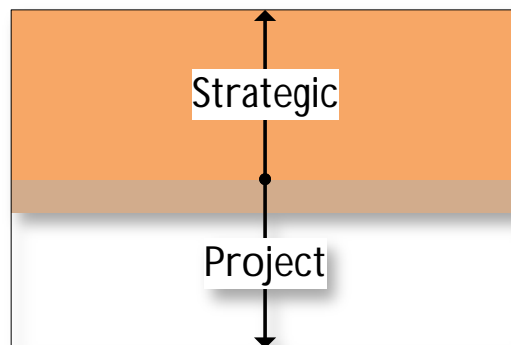

**Keypoint**  
The EA framework you choose, depends on what you want from your EA framework.

**Adoption**  
EA Project Team: Decide what you want from an EA framework.



What framework would be a good choice if you favour one that provides Project guidance and Detail, rather than Strategic guidance and Usability?

		Weighting	TOGAF	Zachman	PEAF
Transformation Focus	Strategic	5%	0.1	0.4	0.5
	Project	40%	2	3.2	0.8
Structural Focus	Enterprise	5%	0.1	0.1	0.5
	IT	5%	0.5	0.5	0.5
Content	Detail	40%	3.2	0.4	1.6
	Usability	5%	0.05	0.05	0.5
Total		100%	5.95	4.65	4.4

**Keypoint**  
 If you favour Project guidance and Detail, rather than Strategic guidance and Usability – then TOGAF is clearly for you.

What framework would be a good choice if you favour one that provides Strategic guidance and Usability, rather than Project guidance and Detail?

**Keypoint**  
 If you favour Strategic guidance and Usability, rather than Project guidance and Detail – then PEAFF is clearly for you.

		Weighting	TOGAF	Zachman	PEAF
Transformation Focus	Strategic	30%	0.6	2.4	3
	Project	10%	0.5	0.8	0.2
Structural Focus	Enterprise	10%	0.2	0.2	1
	IT	10%	1	1	1
Content	Detail	10%	0.8	0.1	0.4
	Usability	30%	0.3	0.3	3
<b>Total</b>		<b>100%</b>	<b>3.4</b>	<b>4.8</b>	<b>8.6</b>

# How do POET and PEAFF relate to the TOGAF ADM Phases?

Just done your *TOGAF*<sup>®</sup> training?  
Great! Now what?

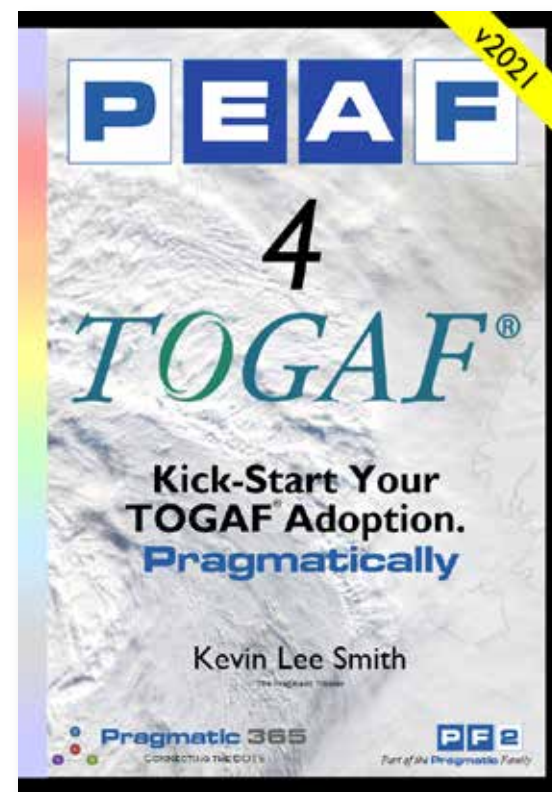

**Keypoint**  
PEAF provides the Bootstrap to kickstart your TOGAF adoption.

**Adoption**  
Enterprise Architect: Use PEAFF to set the context, to decide what parts of TOGAF to use where and when.



# How do TOGAF and PEAFF compare, regarding Framework content vs Benefits realised?

## Framework Content

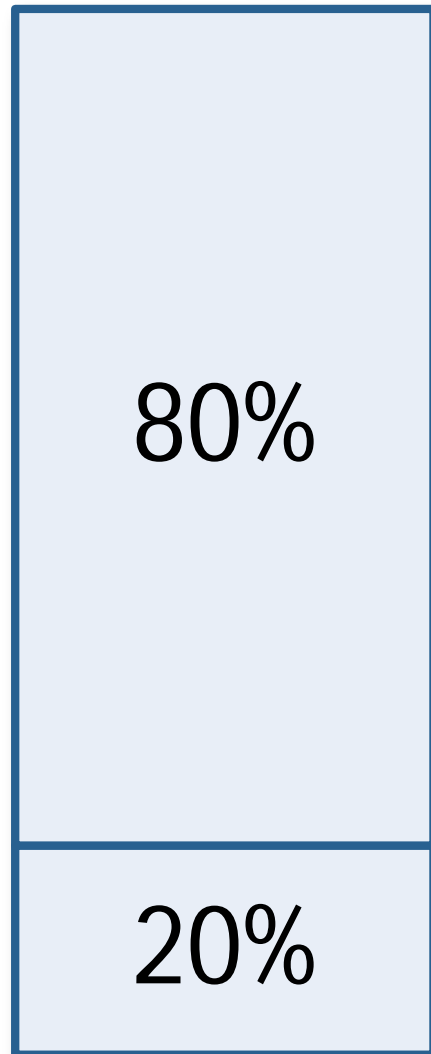

*TOGAF*<sup>®</sup>

**PEAF**<sup>™</sup>

## Benefits Realised

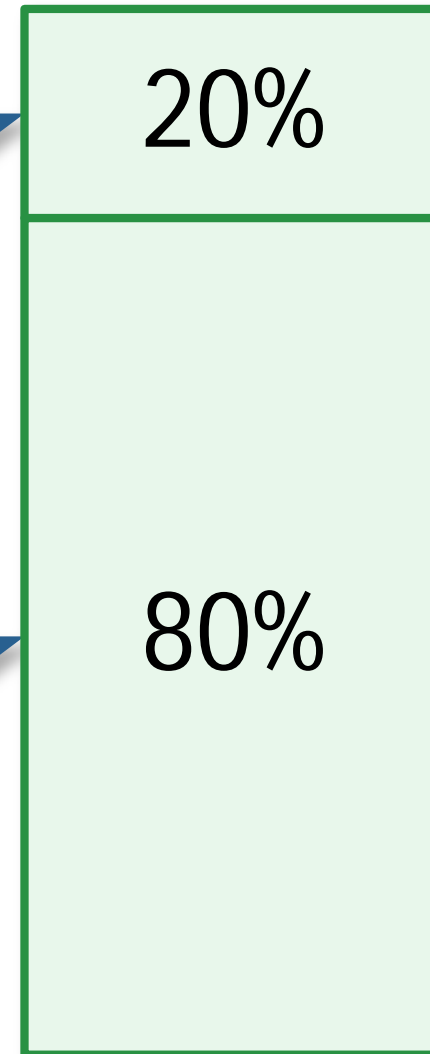

**Keypoint**  
 PEAFF provides the 20% (fundamentals) that yields 80% of the benefit.  
 TOGAF provides the 80% (details), that yields 20% of the benefit.

**Adoption**  
 EA Project Team:  
 Utilise PEAFF to put in place the 20% (fundamentals) that yields 80% of the benefit.



# How does PF2 map to TOGAF?

				
PART I Introduction	Introduction Frameworks	Language Ontologies		
PART II Architecture Development Method		Adoption	Adoption MAGIC	Adoption MAGIC
PART III ADM Guidelines & Techniques			Adoption MAGIC	Adoption MAGIC
PART IV Architecture Content Framework			Adoption MAGIC	Adoption MAGIC
PART V Enterprise Continuum & Tools			Adoption MAGIC	Adoption MAGIC
PART VI Architecture Capability Framework		Adoption	Adoption MAGIC	Adoption MAGIC

**Keypoint**  
PEAF covers  
the whole of  
TOGAF and  
more.

**Adoption**  
Enterprise Architect:  
Understand which  
parts of PEAFF to  
use to aid TOGAF.

# How do POET and PEAFF relate to the TOGAF ADM Phases?

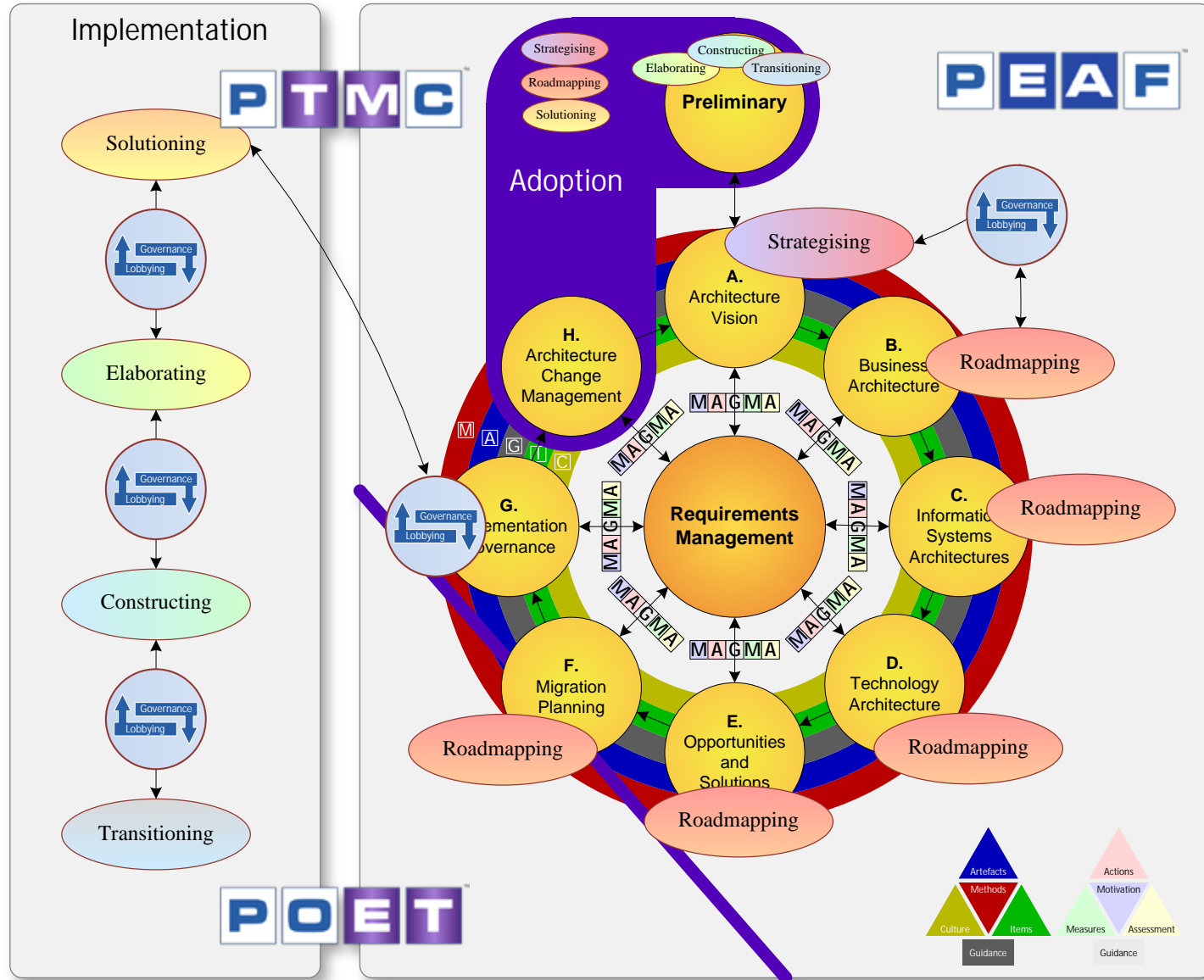

“PEAF is an EA bootstrap”

- Chris Forde  
 General Manager Asia Pacific &  
 VP Enterprise Architecture  
 The Open Group

**Keypoint**  
 Start with POET and PEAFF, and then move on to TOGAF if required.

**Adoption Enterprise Architect:** If using TOGAF, use PEAFF as a bootstrap

# How does Zachman, relate to POET?

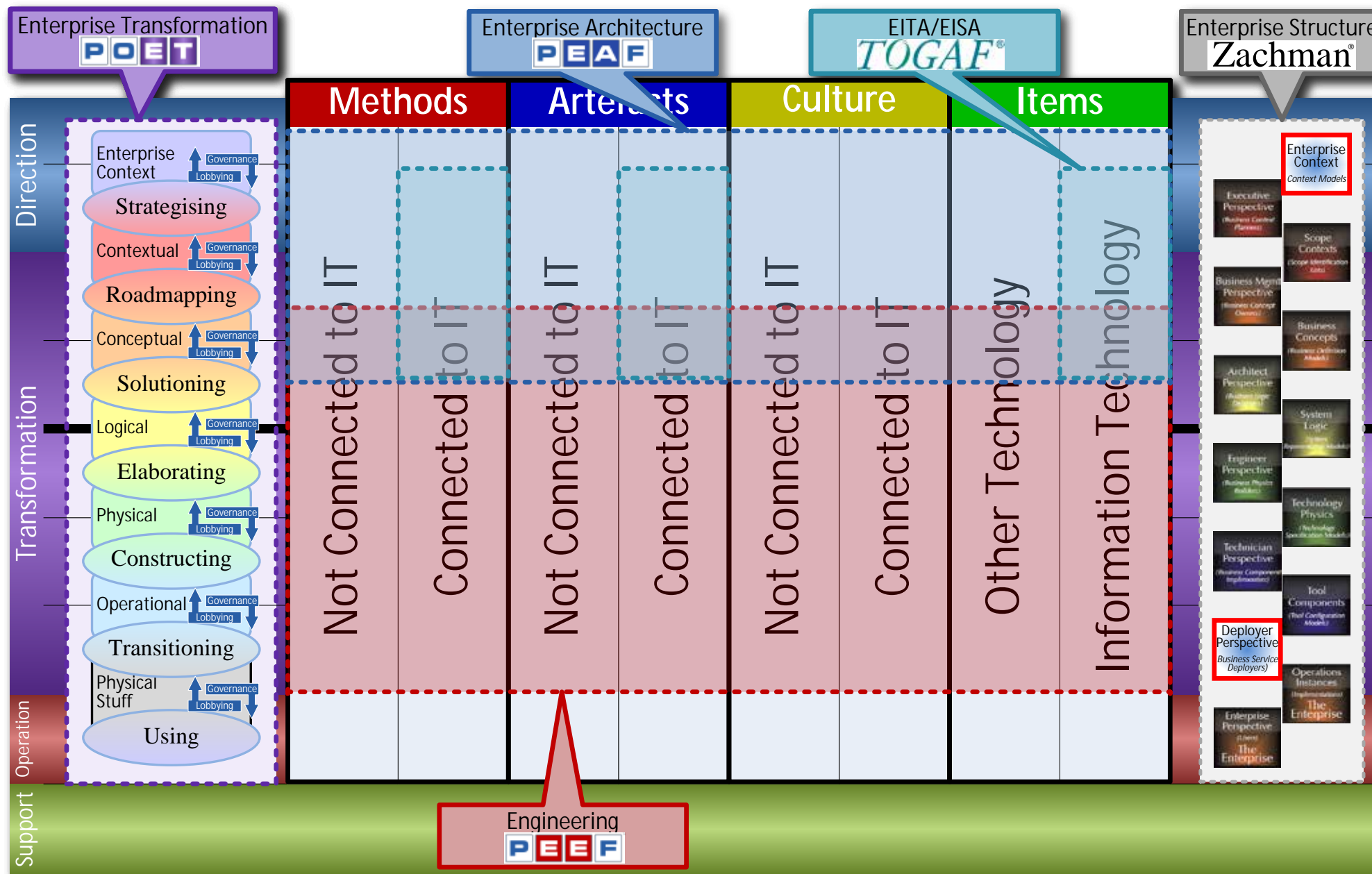

**Keypoint**  
 POET provides an Operating model for how Zachman, TOGAF, PEARF, COBIT, ITIL (and all other Transformation frameworks) relate to each other.

**Adoption**  
 EA Project Team: Use POET as a canvas to understand how other frameworks you use, relate to each other.

# How does COBIT, relate to POET?

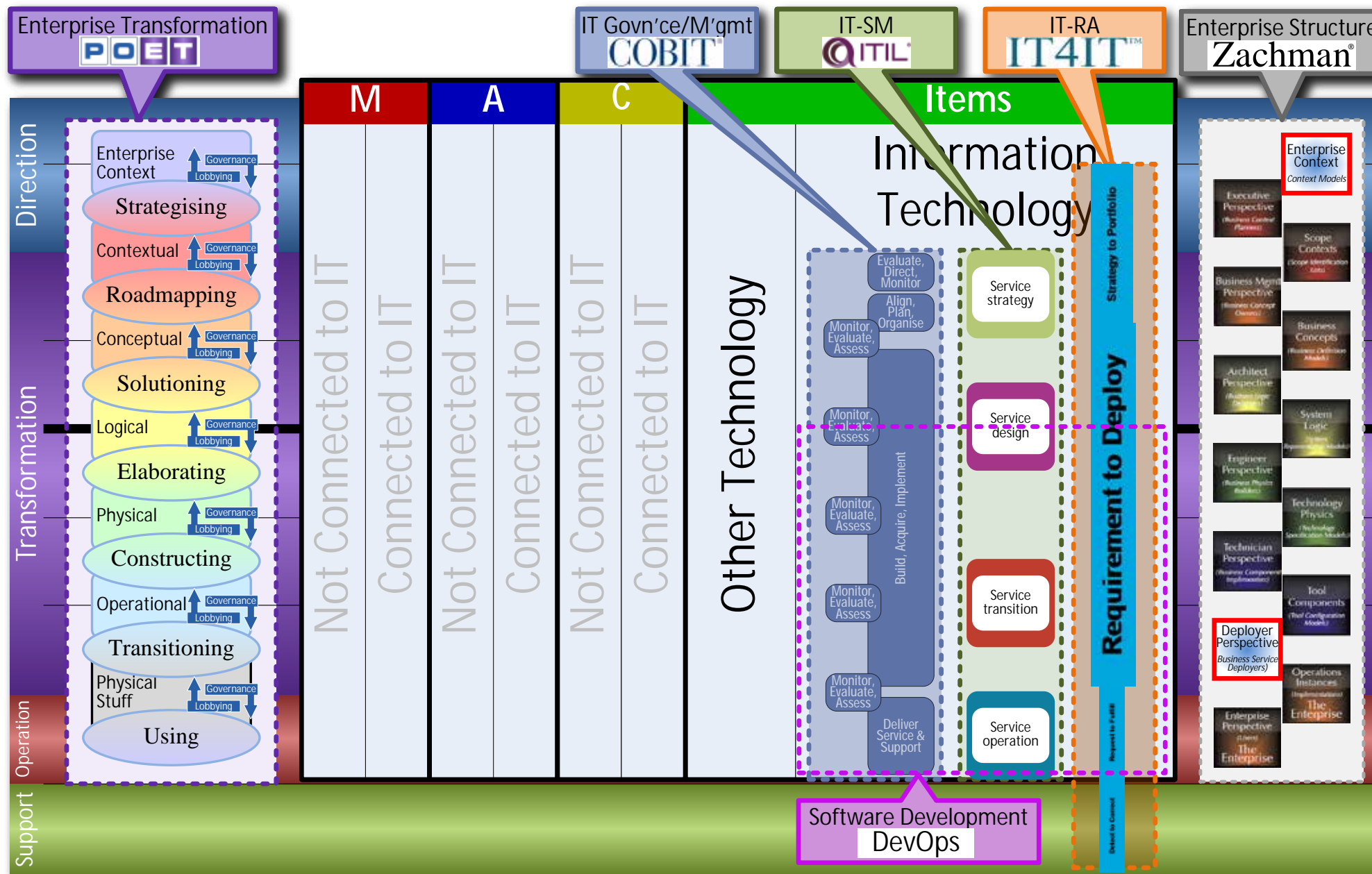

**Keypoint**  
 Frameworks that span multiple domains (Transformation, Operation and Support) fragment the Enterprise.

**Adoption Management:**  
 Consider using frameworks oriented around DOTS.





# What is the level of detail that Zachman, POET, PEAFF and TOGAF provide?

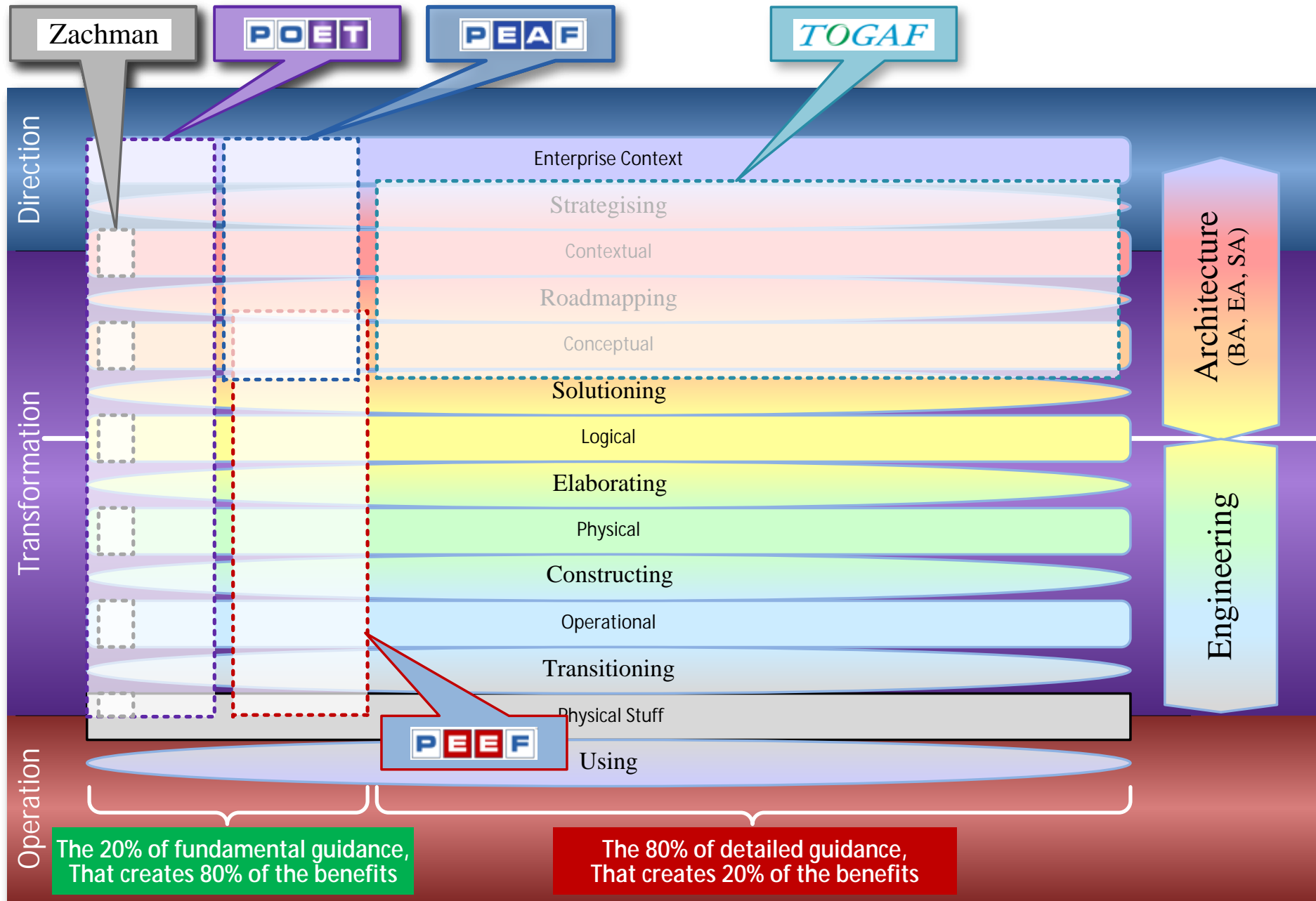

**Keypoint**  
 POET/PEAFF/PEEF provides the 20% (fundamentals) that yields 80% of the benefit. TOGAF provides the 80% (details), that yields 20% of the benefit.

**Adoption**  
 Management: Decide what is more important – A) The 20% (fundamentals) that yields 80% of the benefit, or B) the 80% (details), that yields 20% of the benefit.

# How do TOGAF and PEAFF compare in terms of a Google Trend Analysis?

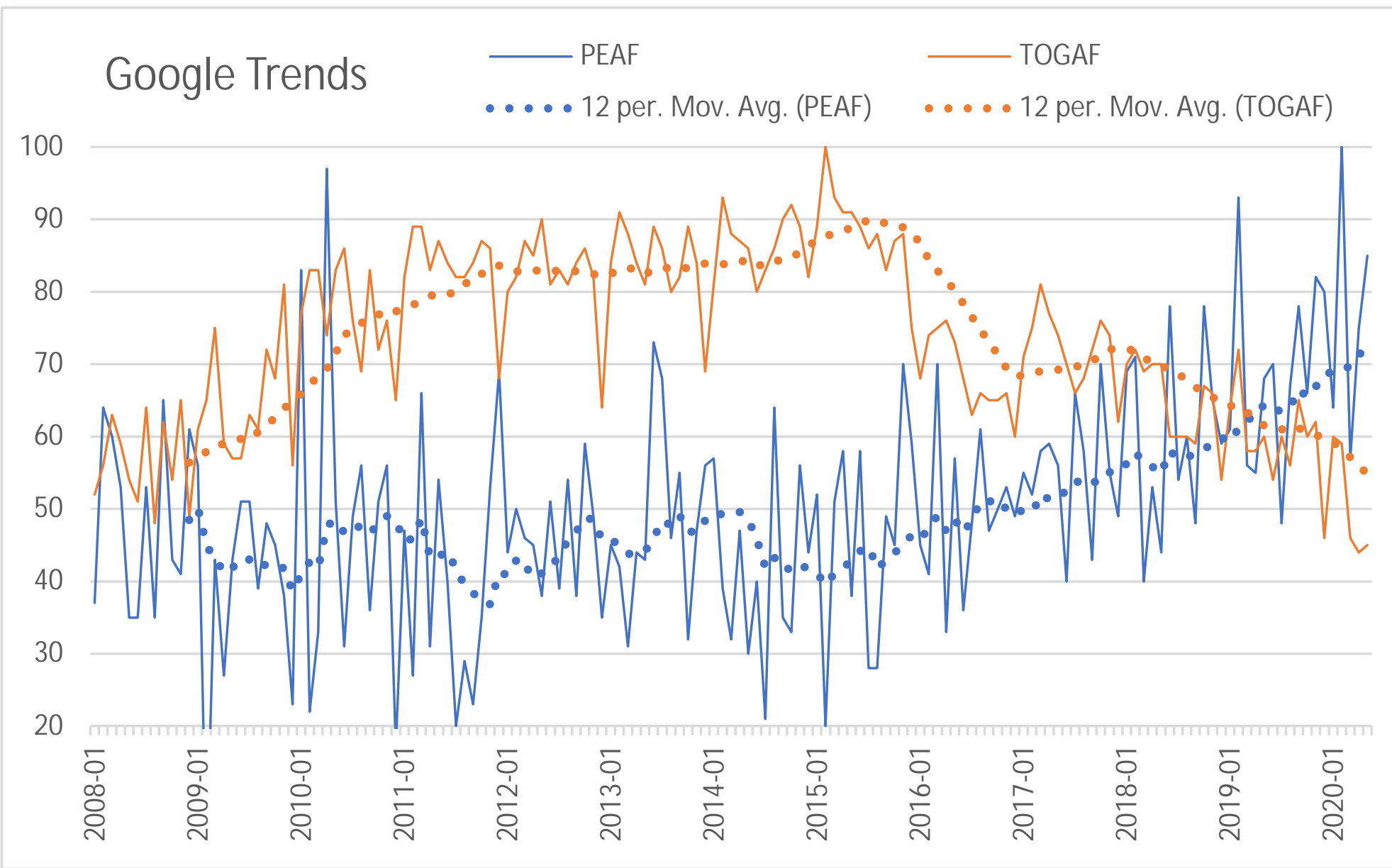

**Keypoint**  
 The trend for TOGAF is falling.  
 The Trend for PEAFF is rising.

**Adoption Management:**  
 Investigate why demand for TOGAF is falling, while demand for PEAFF is rising.

# What are the basic concepts that POET takes from Zachman and builds on?

## The Zachman Framework for Enterprise Architecture™

### The Enterprise Ontology™

Version 3.0

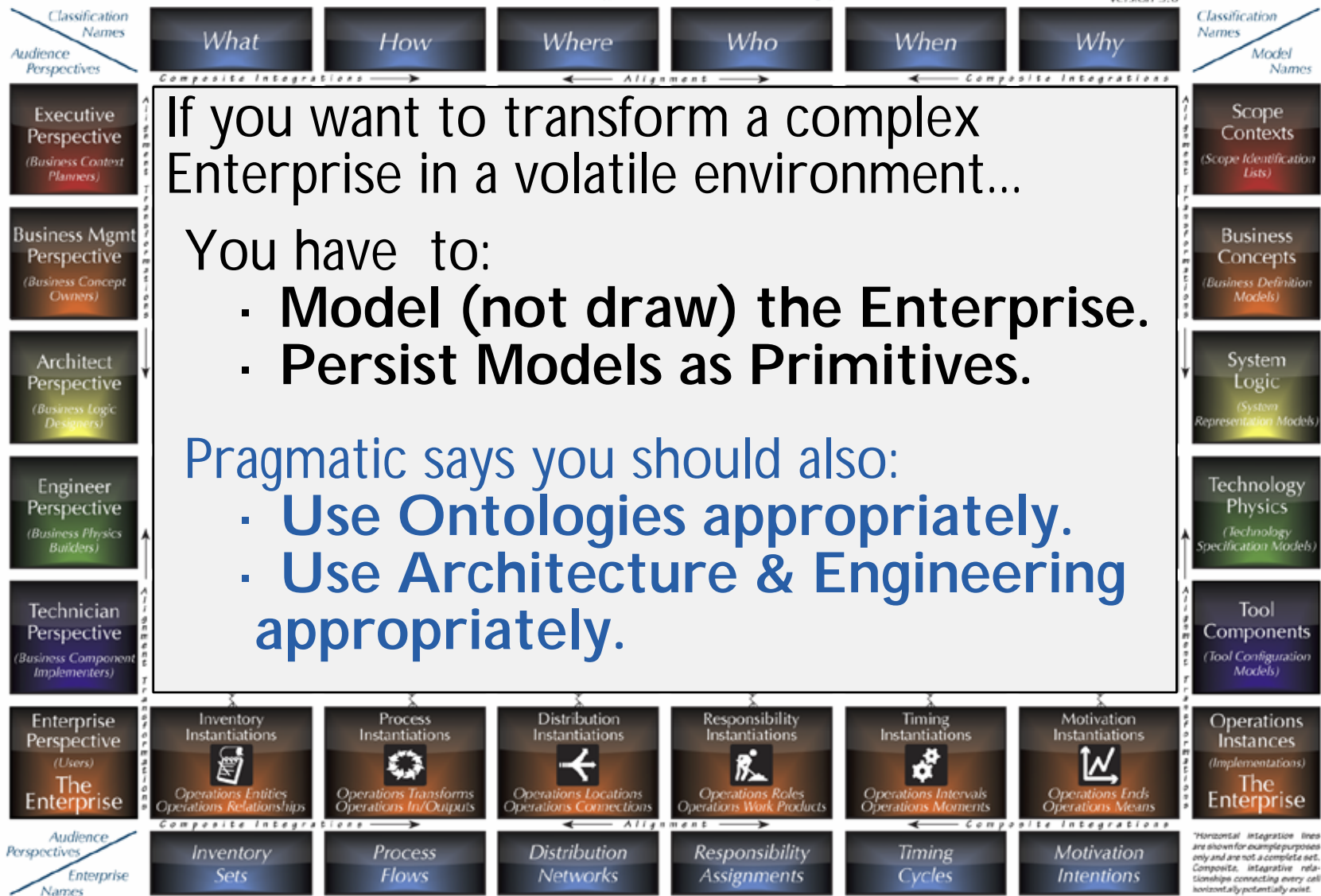

If you want to transform a complex Enterprise in a volatile environment...

You have to:

- Model (not draw) the Enterprise.
- Persist Models as Primitives.

Pragmatic says you should also:

- Use Ontologies appropriately.
- Use Architecture & Engineering appropriately.

**Keypoint**  
 You can't change what you don't understand.  
 You can't understand what you can't see.

**Adoption**  
 Management: Decide to move away from unstructured information, and towards modelling structured primitives.

© 1987-2011 John A. Zachman, all rights reserved. Zachman® and Zachman International® are registered trademarks of John A. Zachman



# What is the Phase (Perspective) that POET includes that the Zachman Ontology does not?

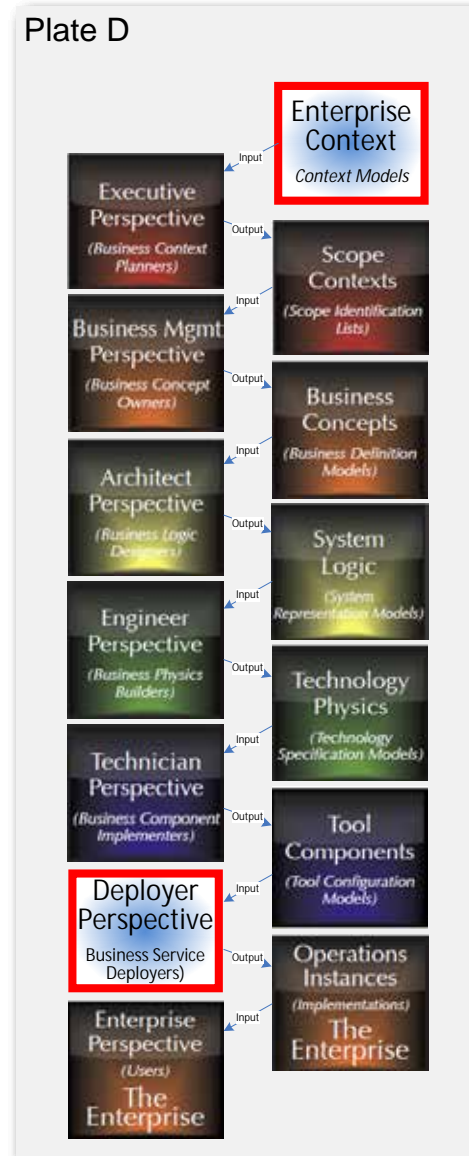
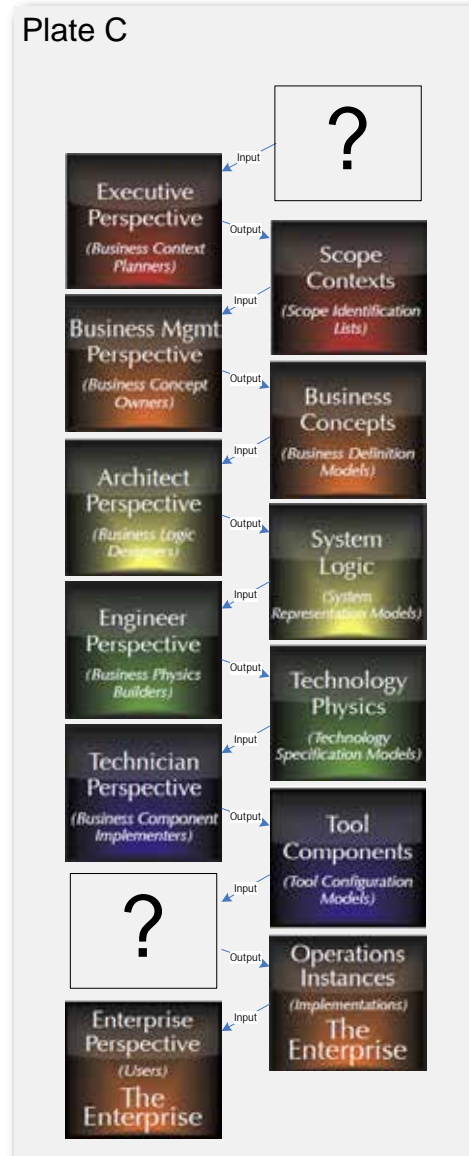
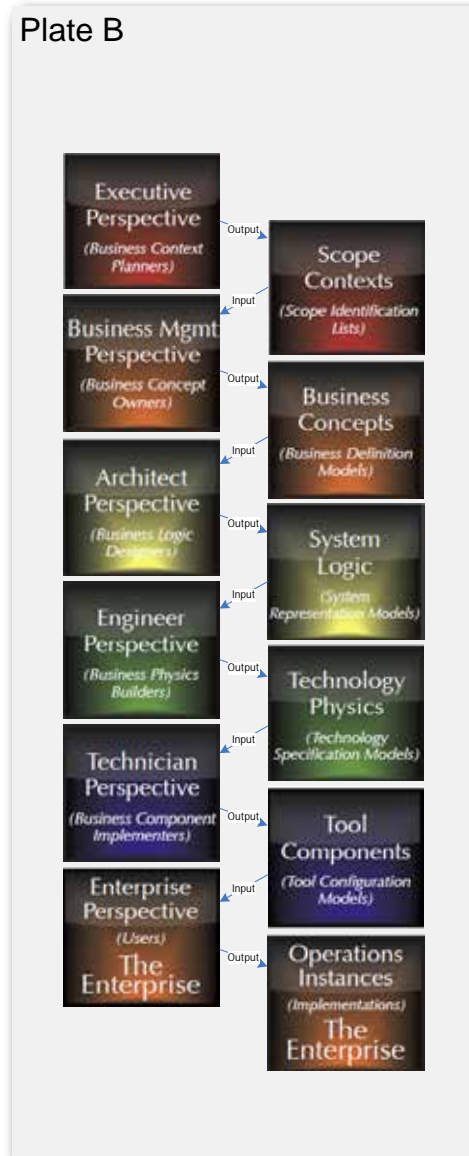

**Keypoint**  
 In the Zachman Framework/Ontology, the Deployer perspective is missing.

**Adoption**  
 Enterprise Architect: Be aware that the Deployer perspective is missing.



# Is POET too high level (and therefore of little value)?

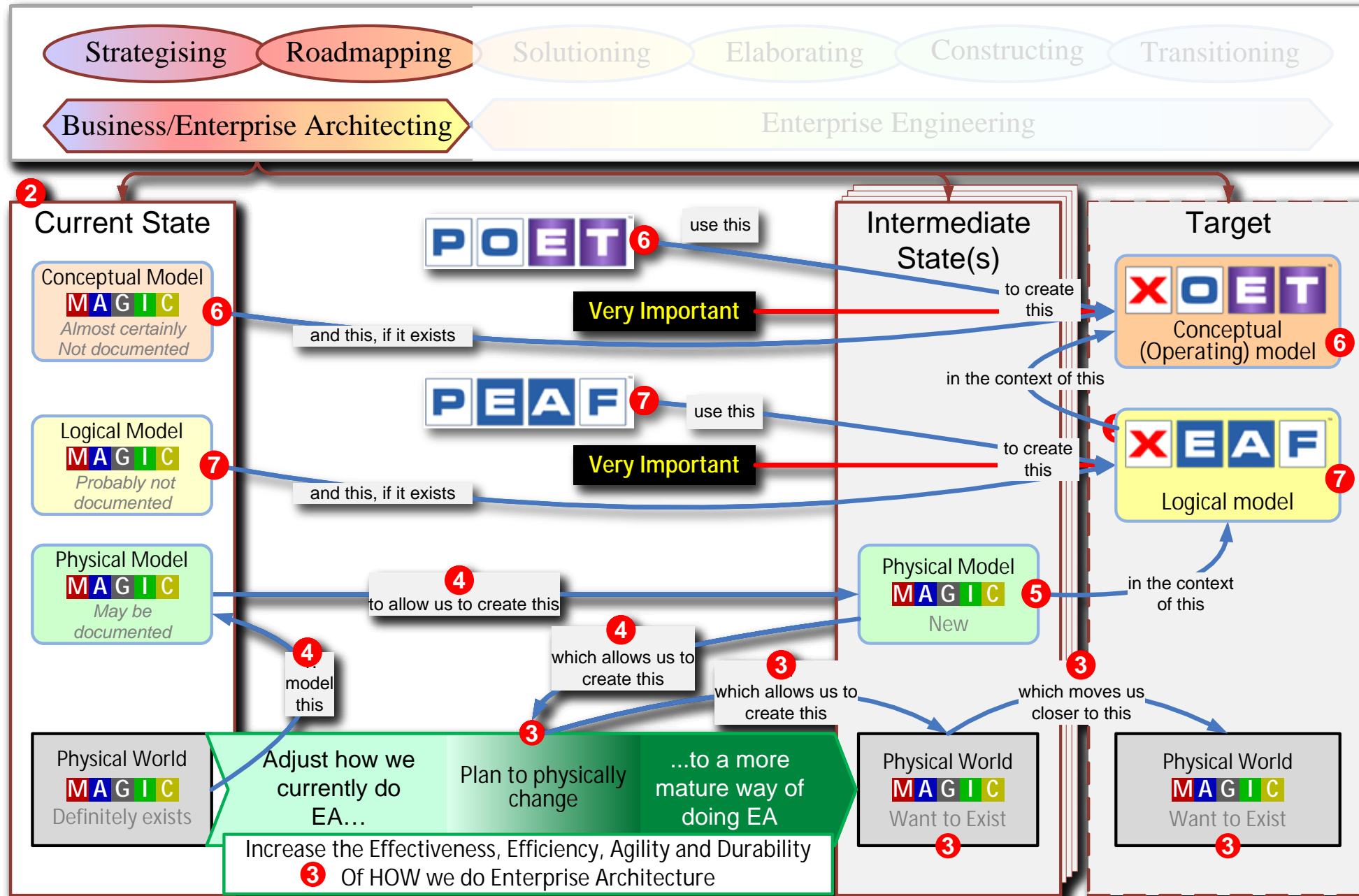

**Keypoint**  
Use POET as a conceptual guide.

**Adoption**  
EA Project Team: Use POET as the Conceptual target, to figure out the physical changes required to your Transformation capability's Methods, Artefacts, Culture and Environment.



# How is POET supposed to be used?

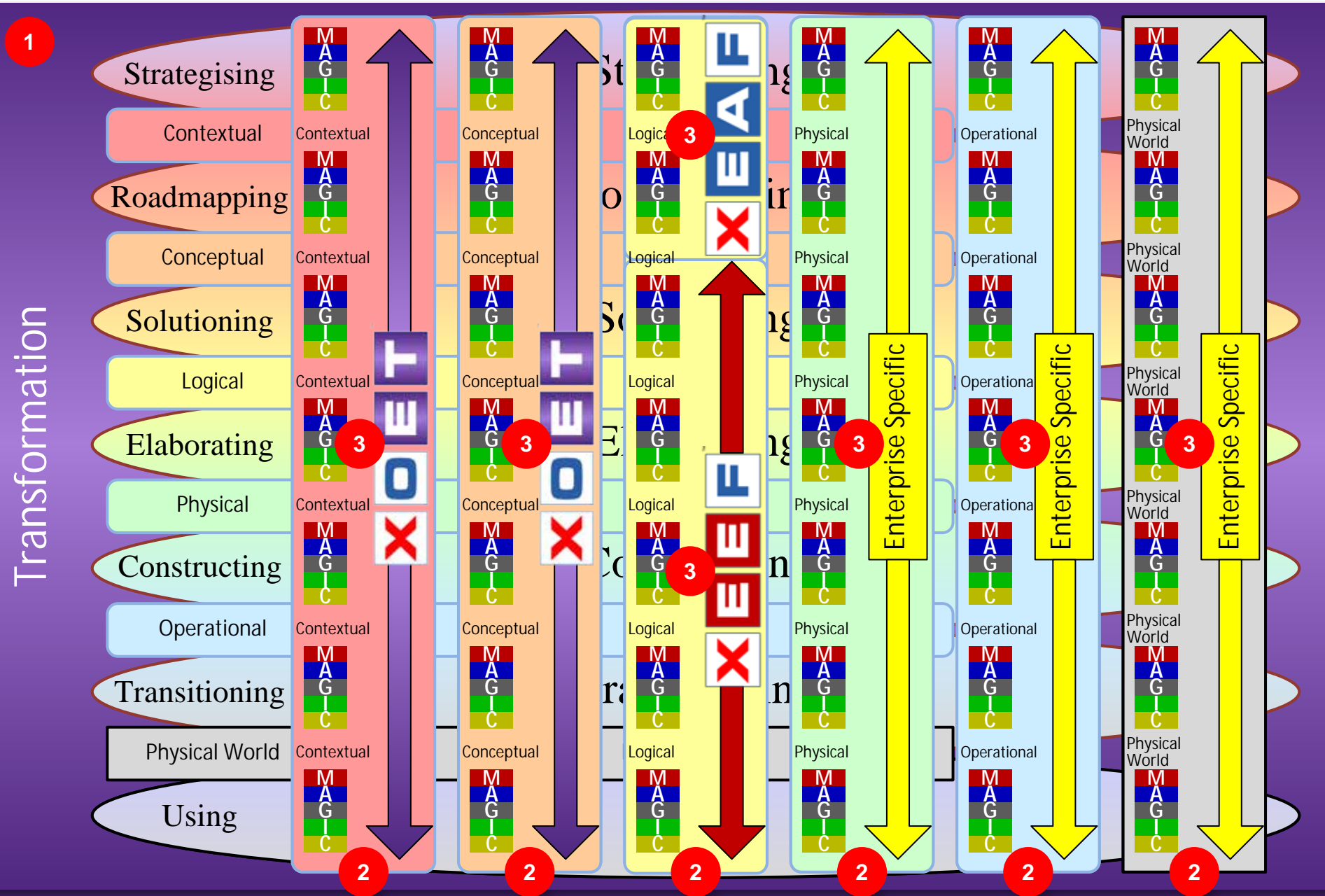

**Keypoint**  
 Use POET as a Contextual / Conceptual guide.  
 Use PEAF as a logical guide.

**Adoption**  
 EA Project Team: Use PEAF as the Logical target, to figure out the physical changes required to your EA capability's Methods, Artefacts, Culture and Environment.

# What does PEEF define help you cope with?



**Pragmatic Framework**

**Enterprise  
Fundamentals**

**Keypoint**  
Fundamentals are  
fundamentally  
important.

Doh!

**Adoption**  
Management: Instigate  
a project to ensure  
everyone related to  
Transformation is  
trained in PEEF/XEFF.

# What does the Language section of PEFF contain?

# Language

## Keypoint

The Language section of PEFF introduces fundamental terminology that is used throughout Pragmatic's Frameworks.



What will the definitions of all the words in Pragmatic's Frameworks and Ontologies, be consistent with?

## FACT 1

I guarantee that **SOME** or **ALL** of the words used here will **NOT** be consistent with your current definitions.

## FACT 2

I guarantee that **ALL** of the words used here **ARE** consistent within this framework.

### Keypoint

Be ever vigilant of the hidden confusion that language can create.

### Adoption

EA Project Team:  
Create a data dictionary for all the terms used in the Enterprise's Transformation Capability.



# What is a System?

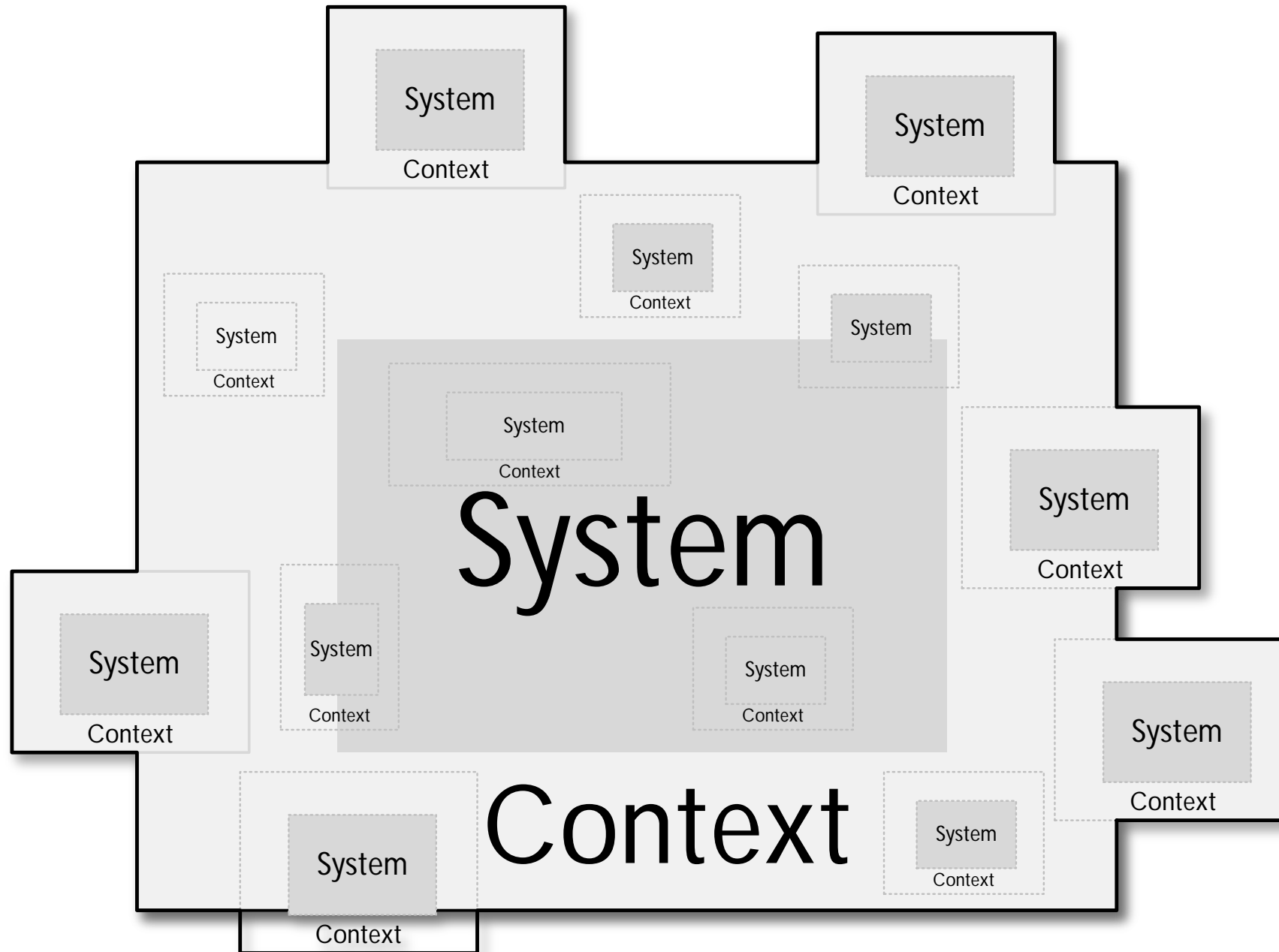

**Keypoint**  
**Everything**  
**is a System.**

## Adoption

EA Project Team: Add the definition of "System" to the data dictionary used in the Enterprise's Transformation Capability.



# What does the word “Enterprise” mean?

Government

Public  
Private  
Partnerships

Company, Business,  
Corporation,  
Conglomerate,  
Organisation, SME,  
Firm, Establishment,  
Group, Multinational  
or Venture.

For Profit

Privately Controlled

Publicly Controlled

Not for Profit

Charity

Mutual

Academic

Religious

Scientific

Artistic

Social

## Keypoint

The Word Enterprise does not mean “large” or “large IT” or “senior”. It is a general noun.

## Adoption

EA Project Team: Add the definition of “Enterprise” to the data dictionary used in the Enterprise's Transformation Capability.



When Pragmatic uses the word “Transformation”, what are we referring to?

Transformation

Conversion

Change

Adjustment

Amendment

Modification

Makeover

Alteration

Renovation

## Keypoint

There is no hidden connotation to Pragmatic’s use of the word “Transformation”.

## Adoption

EA Project Team: Add the definition of “Transformation” to the data dictionary used in the Enterprise's Transformation Capability.

# What is the purpose of a Framework?

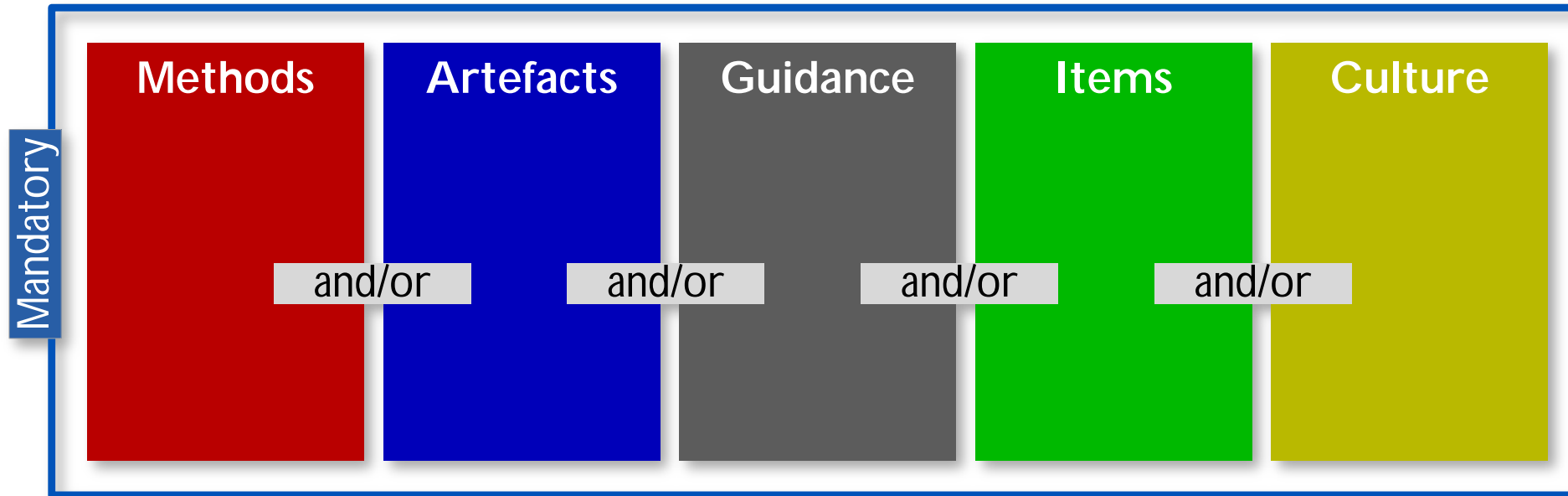

## Keypoint

A Framework is an expression of Best Practice comprising information in at least one area (Methods, Artefacts, Guidance, Items, Culture) and optionally information regarding its Adoption.

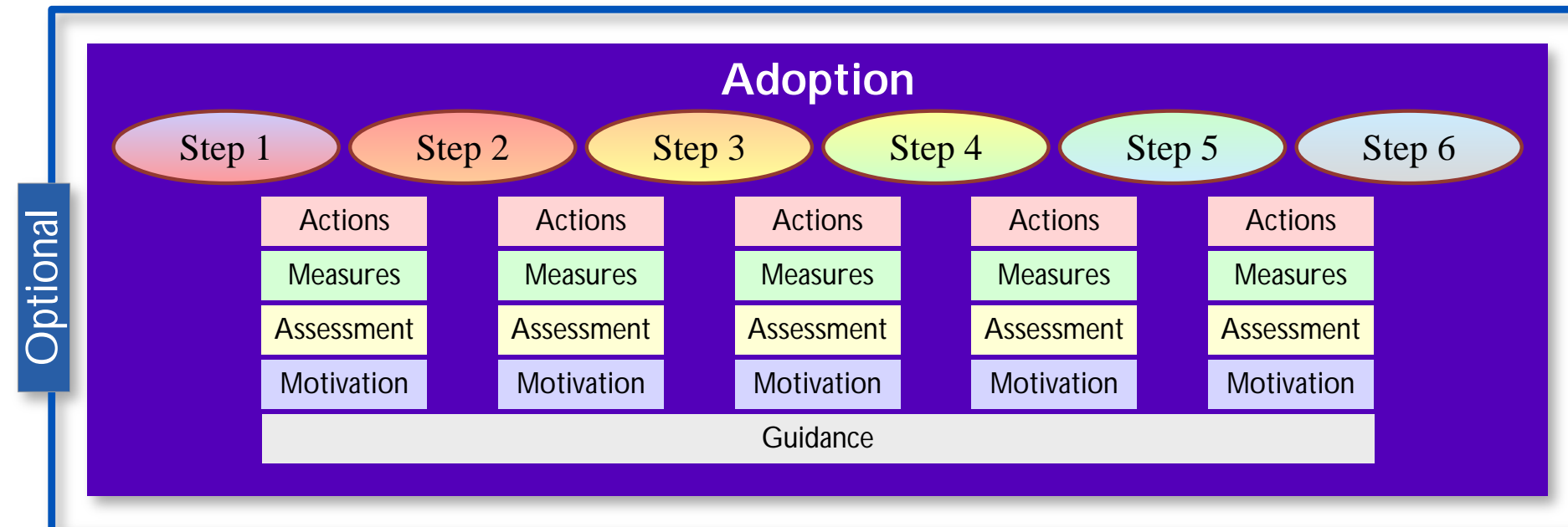

## Adoption

Enterprise Architect:  
Categorise the content of any Framework you use, in terms of Context + MAGIC + Adoption.

# LUNCH!

## Back at 12:59



What is the difference between Theory and Practice and how are they related?

“In theory, there is no difference between theory and practice.

But, in practice, there is.”

- Jan L. A. van de Snepscheut / Yogi Berra

## Keypoint

Theory is just as important as Practice

## Adoption

Management:  
Don't dismiss theory as not important.





# Why do Pragmatic's Frameworks use a lot of colour?

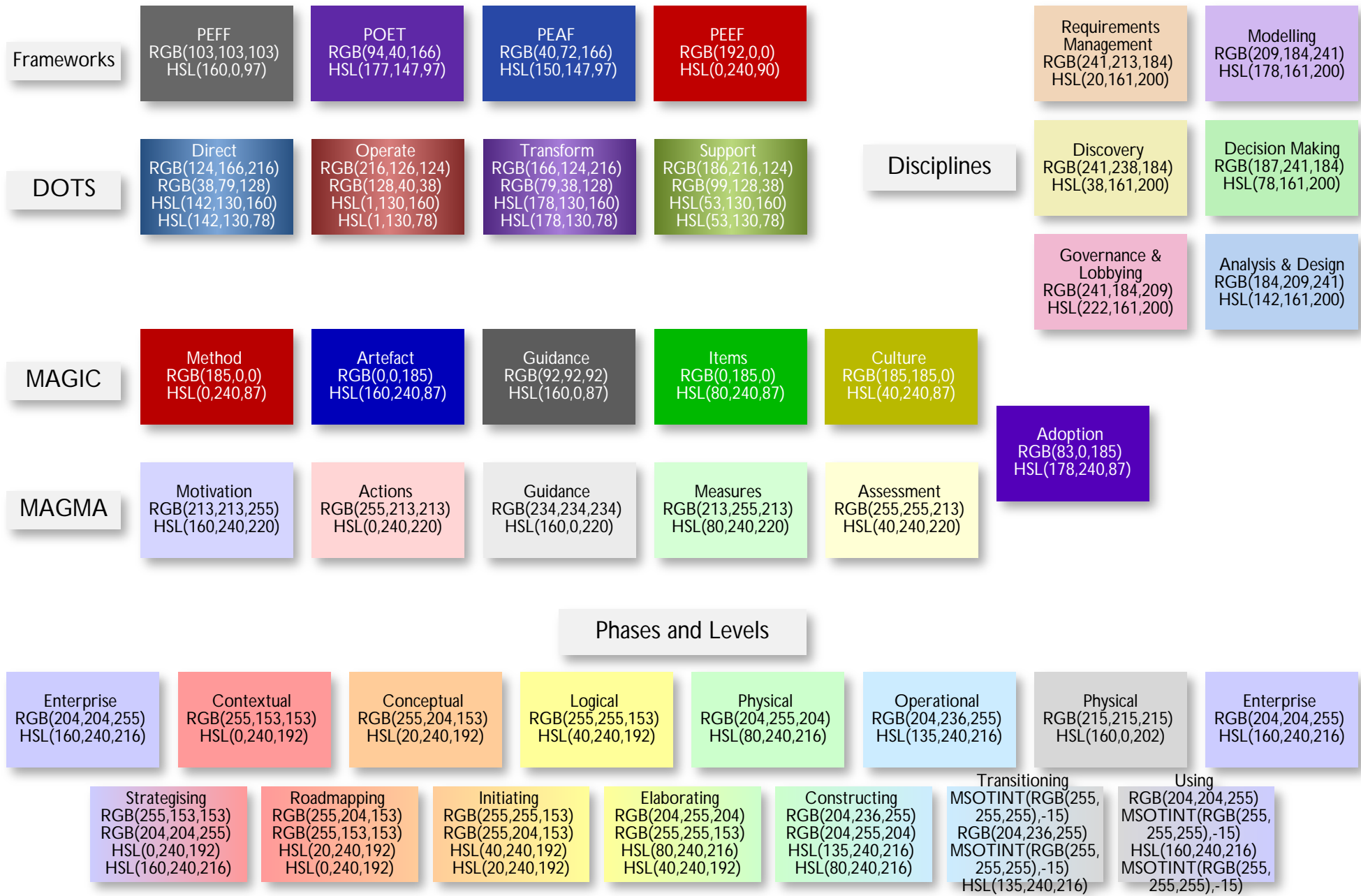

**Keypoint Colour = Information = Understanding.**

**Adoption EA Project Team: Use standardised colours to mean something.**

# Why is the 80/20 rule part of being Pragmatic?



Effort 20%

80%  
Effects

## Keypoint

Concentrate on the 20% that causes 80% of the good effects.

## Adoption

Management: Provide Workers the resources, mandate and encouragement to continuously prioritize the 20% that generates 80% of the benefit.

# Why is Efficiency part of being Pragmatic?

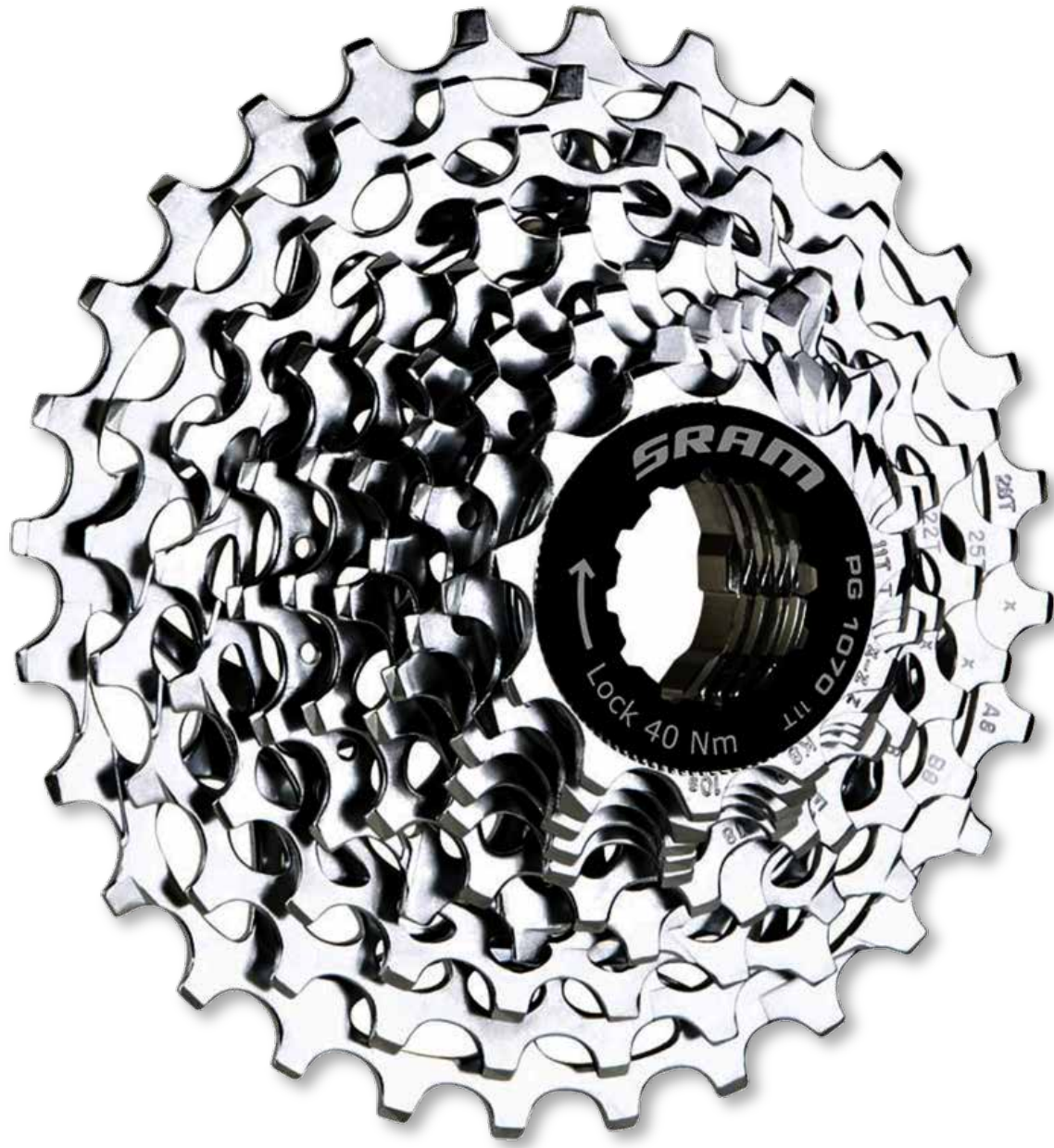

## Keypoint

Just doing the right things is no longer enough. You also need to do them in the right way.

## Adoption

Management: Provide Workers the resources, mandate and encouragement to continuously make their job, and the jobs of their colleagues, more efficient.

# Why is Quality Time part of being Pragmatic?

	Urgent	Not Urgent
Important	<b><u>Firefighting</u></b> e.g. Crises and Deadlines.	<b><u>Quality Time</u></b> e.g. Preventative Maintenance.
Not important	<b><u>Distractions</u></b> e.g. Phones, Emails, Interruptions.	<b><u>Relaxing</u></b> e.g. Chatting around the Coffee Machine.

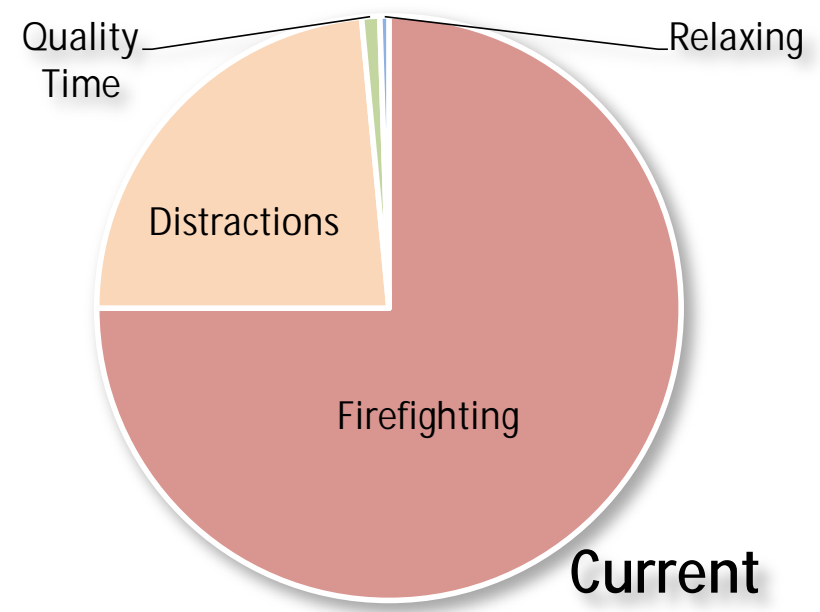

**Keypoint**  
 Important Non-Urgent work, is more important than Important Urgent work.

**Adoption**  
 Management: Provide Workers the resources, mandate and encouragement to spend more time on Important Non-Urgent work (aka Quality Time).



# Why are Fundamentals part of being Pragmatic?



**Keypoint**  
Fundamentals are the foundation on which to build things.



**Adoption**  
Management: Provide Workers the resources, mandate and encouragement to spend more time on getting Fundamentals right.



# Why is Thinking part of being Pragmatic?

thinking

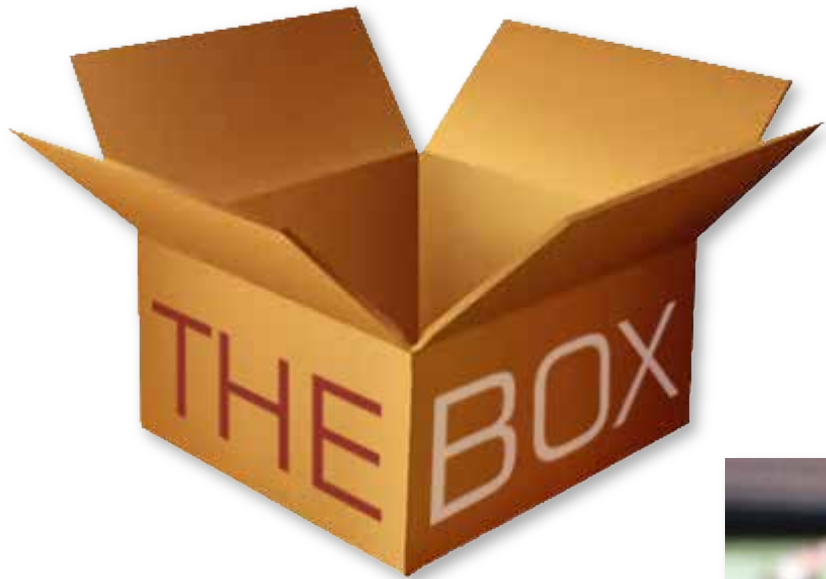

Natural History Museum changes dinosaur display after 10-year-old Charlie Edwards points out their mistake.

**Keypoint**  
Without thinking,  
there can be no  
innovation.

**Adoption**  
Management: Provide  
Workers the resources,  
mandate and  
encouragement to  
spend more time on  
thinking out of the box.

# What stops people being Pragmatic?

The Normal World

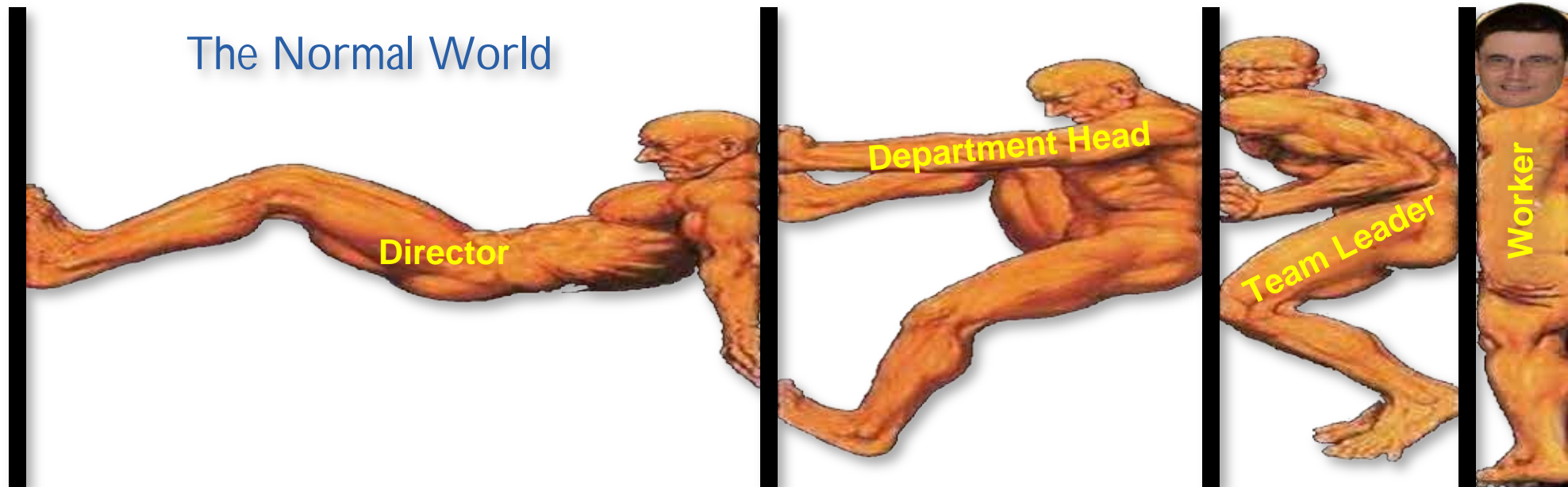

**Keypoint**  
Empowerment  
always beats  
command and  
control.

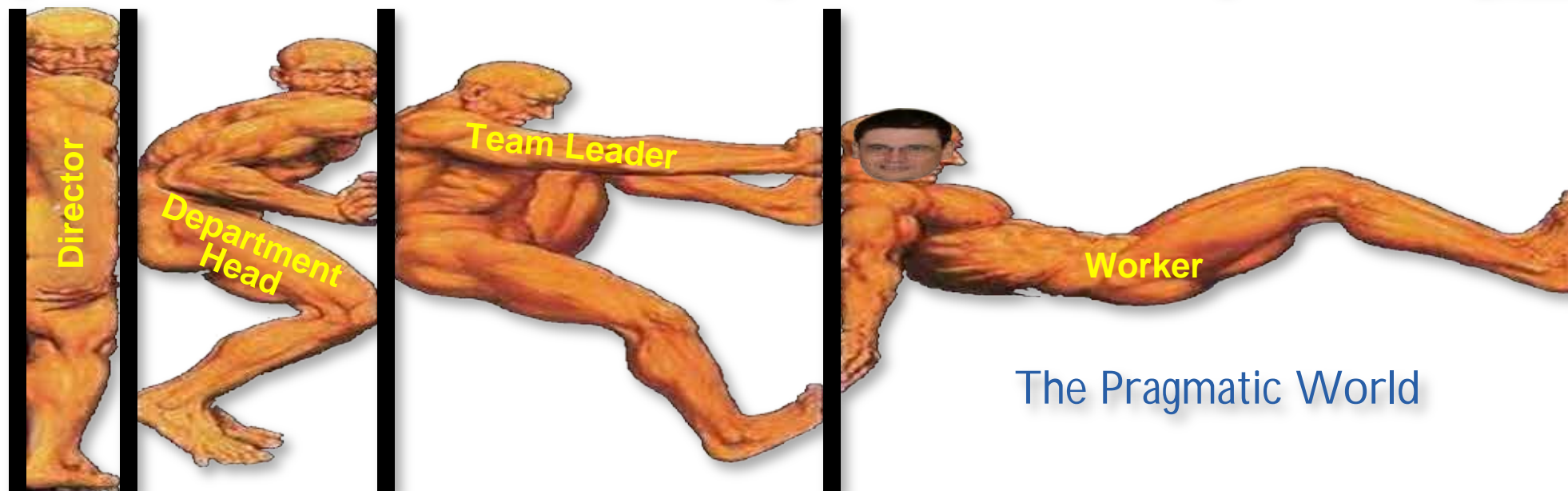

The Pragmatic World

**Adoption**  
Management: Provide  
Workers the resources,  
mandate and  
encouragement to make  
decisions for the benefit of  
the Enterprise, on their  
own.

# Why is Sustainability part of being Pragmatic?

Effectiveness

Efficiency

Quality Time

Today is  
Yesterday's  
Tomorrow

Fundamentals

Thinking

Empowerment

**Keypoint**  
Anything is  
pointless, unless  
it is sustainable.

**Adoption**  
Management: Provide  
Workers the resources,  
mandate and  
encouragement to  
work in a sustainable  
way.

# What does the Ontology section of PEFF contain?

# Ontologies

## Keypoint

The Ontologies section of PEFF introduces fundamental ontologies that are used throughout Pragmatic's Frameworks.





# What are the domains of the Structural Ontology?

# MAGIC™

## The Structural Ontology

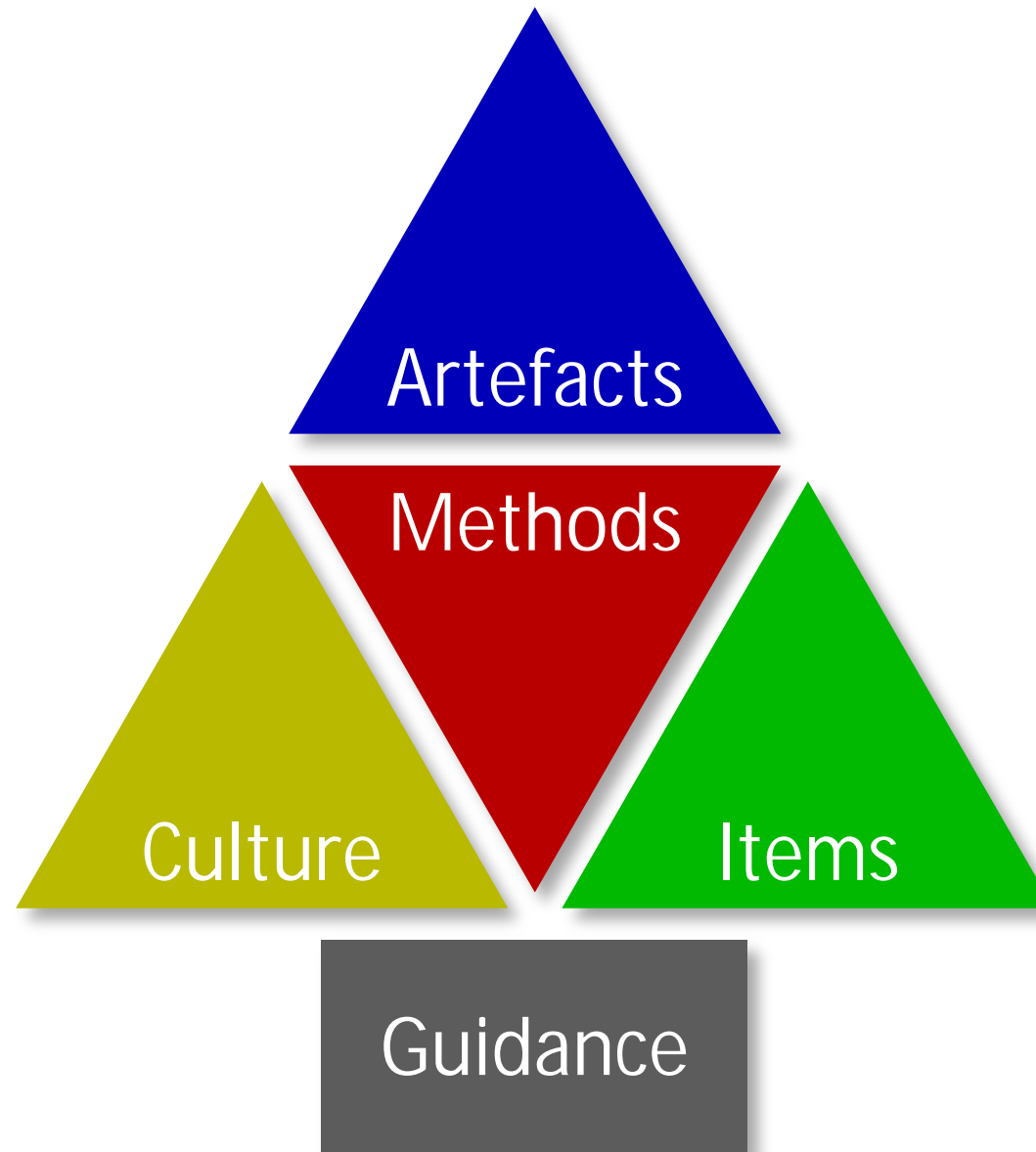

### Keypoint

Methods, Artefacts, Guidance, Items and Culture (MAGIC) is a Structural Ontology

### Adoption

Enterprise Architect: Think about Structural information in terms of Methods, Artefacts, Guidance, Items and Culture (MAGIC).





# How are the five domains of the Structural Ontology related?

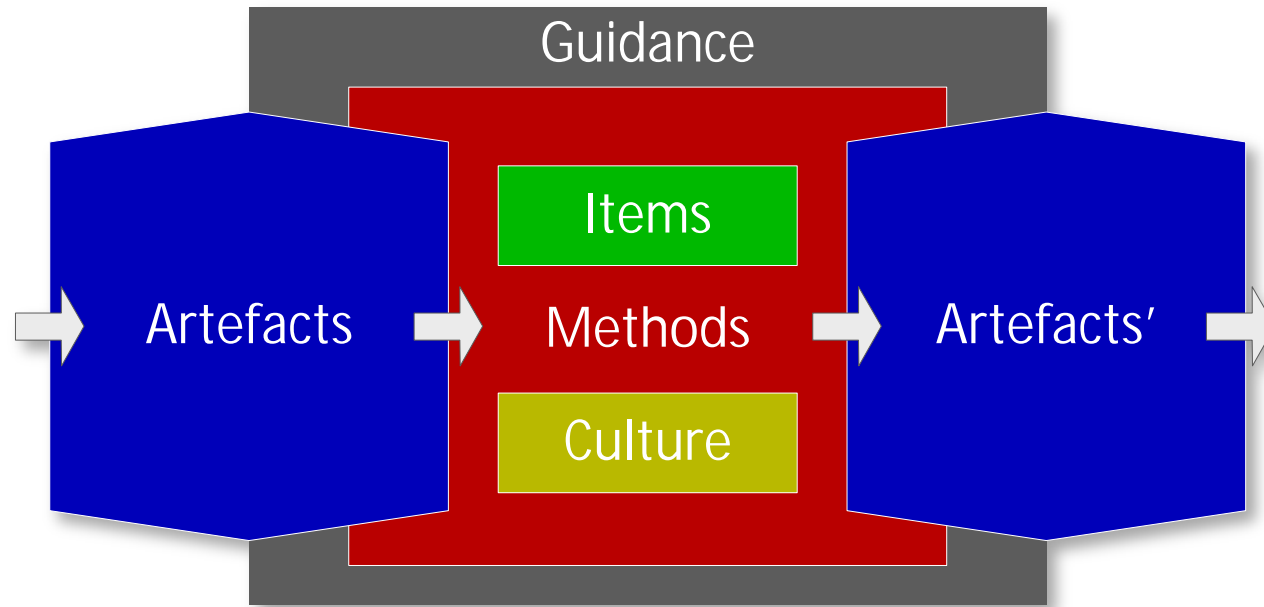
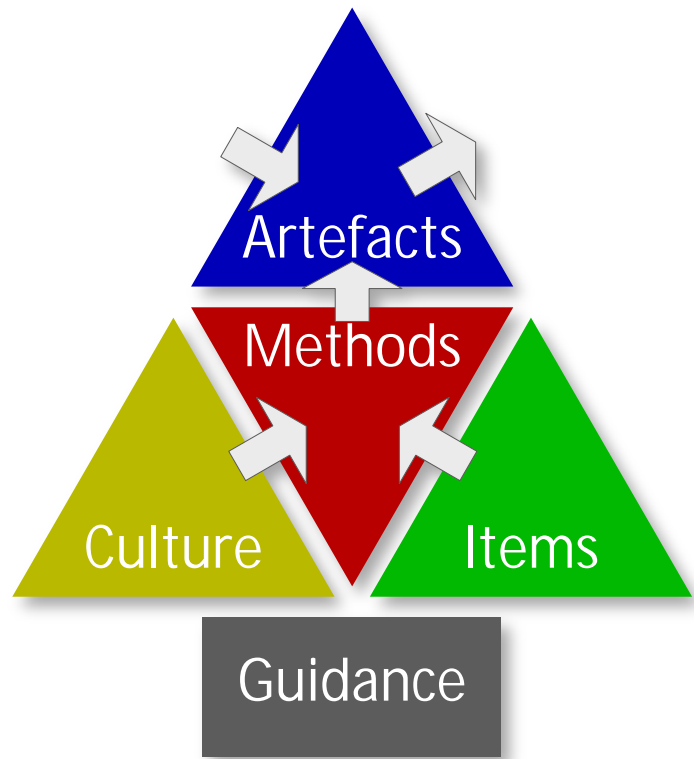

MAGIC™

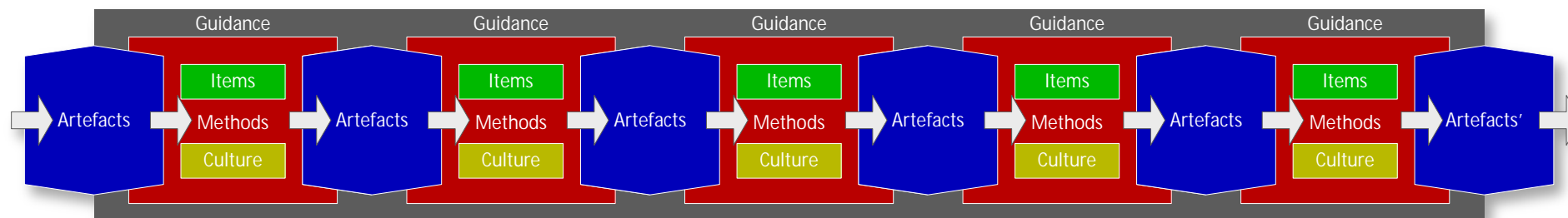

**Keypoint**  
 Methods are executed by Culture (people) and/or Items (things) to transform Artefacts.

**Adoption**  
 Enterprise Architect:  
 Think about Structural information in terms of the flow of Artefacts.

# How are the domains of MAGIC Interrelated?

Domain of Interest

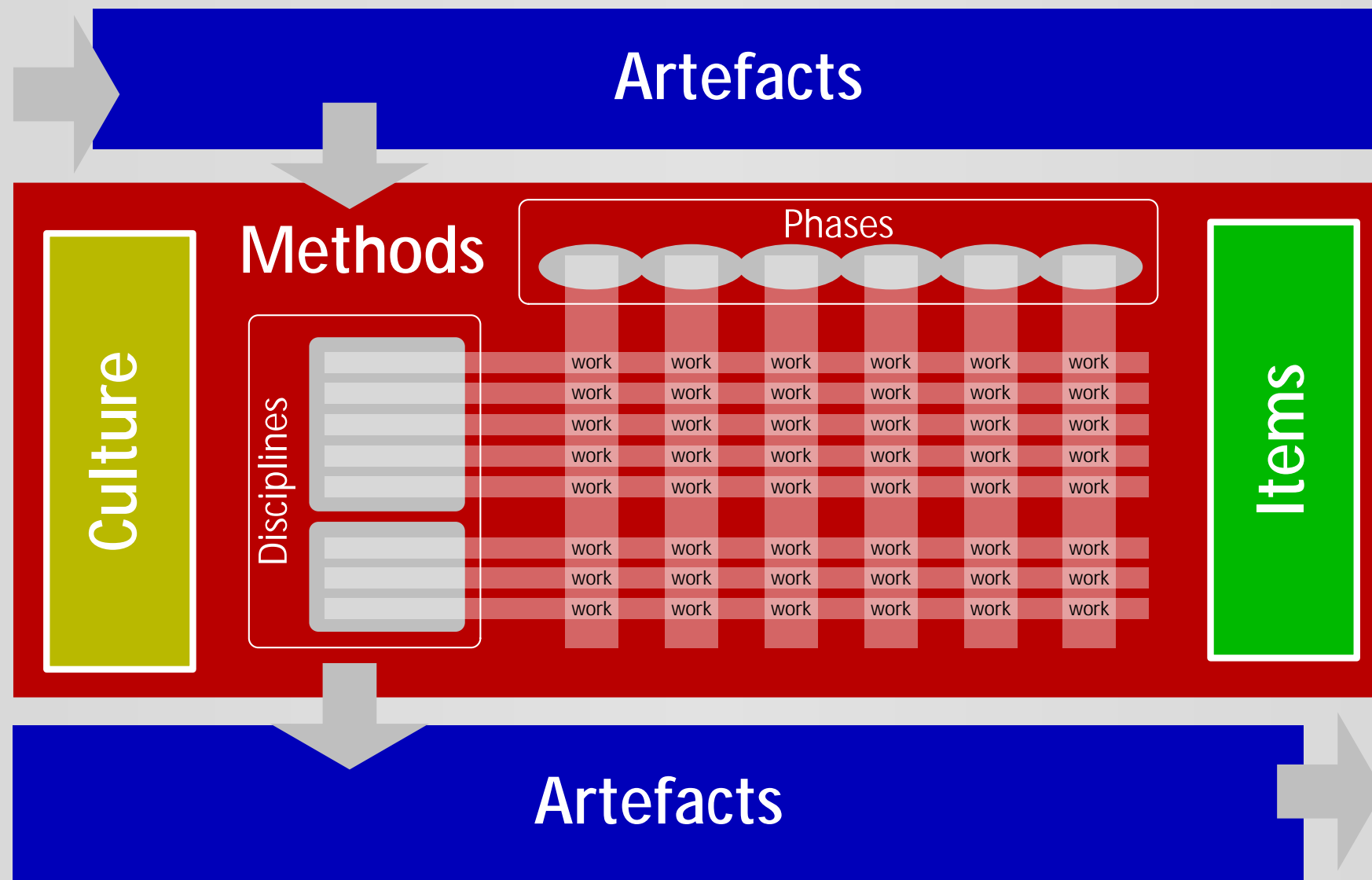

**Keypoint**  
Work is done at the intersection of Phases, Disciplines and Artefacts.

# What are the five domains of the Transformational Ontology?

# MAGMA™

## The Transformation Ontology



### Keypoint

Motivation, Actions, Guidance, Measures and Assessment (MAGMA) is a Transformational Ontology

### Adoption

Enterprise Architect: Think about Transformational information in terms of Motivation, Actions, Guidance, Measures and Assessment (MAGMA).



# How are the five domains of the Transformational Ontology related?

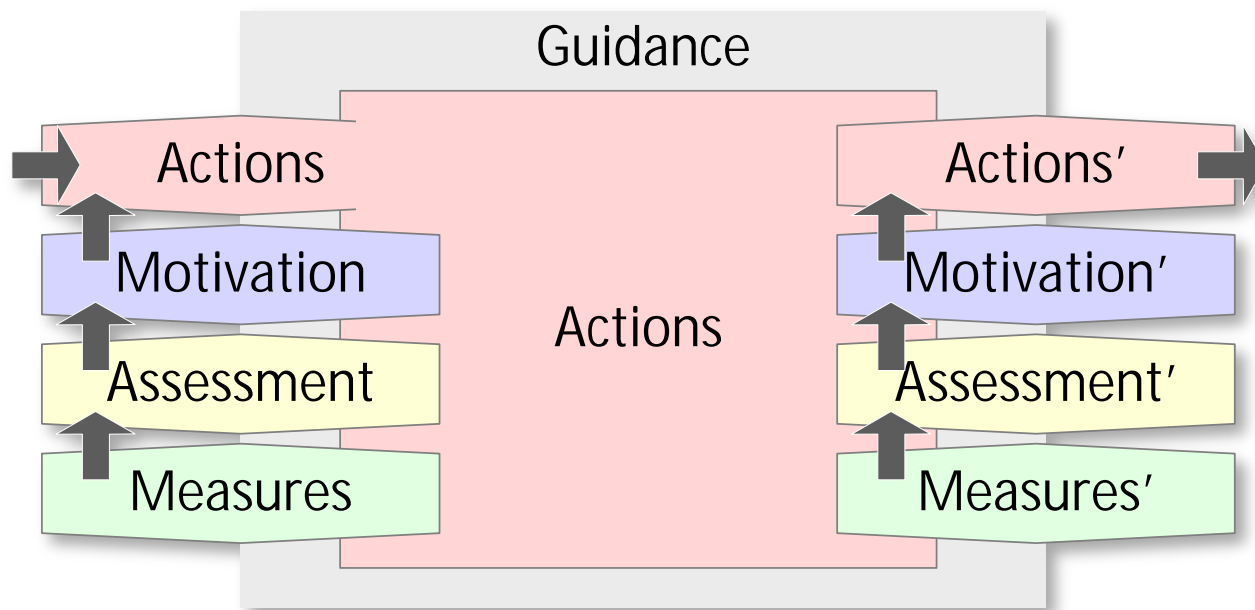

# MAGMA™

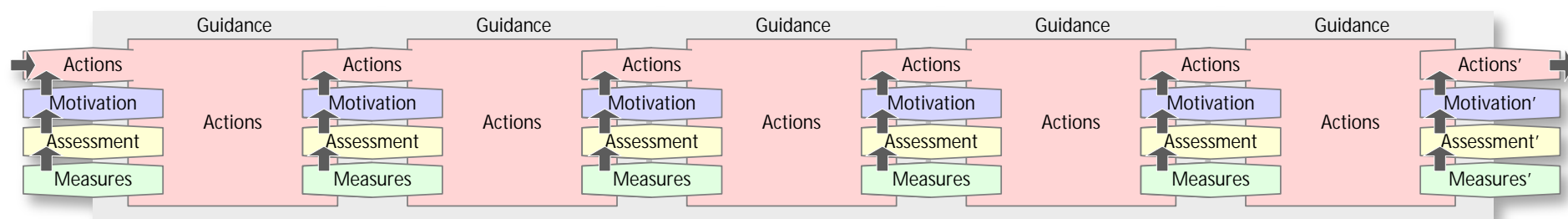

**Keypoint**  
 Measures lead to Assessments lead to Motivation, leads to Actions

**Adoption**  
 Enterprise Architect: Think about Structural information in terms of the flow of Artefacts. Enterprise Architect: Think about Transformational information in terms of the flow of information.

# What are the domains of the Enterprise Ontology?

# DOTS™

## The Enterprise Ontology

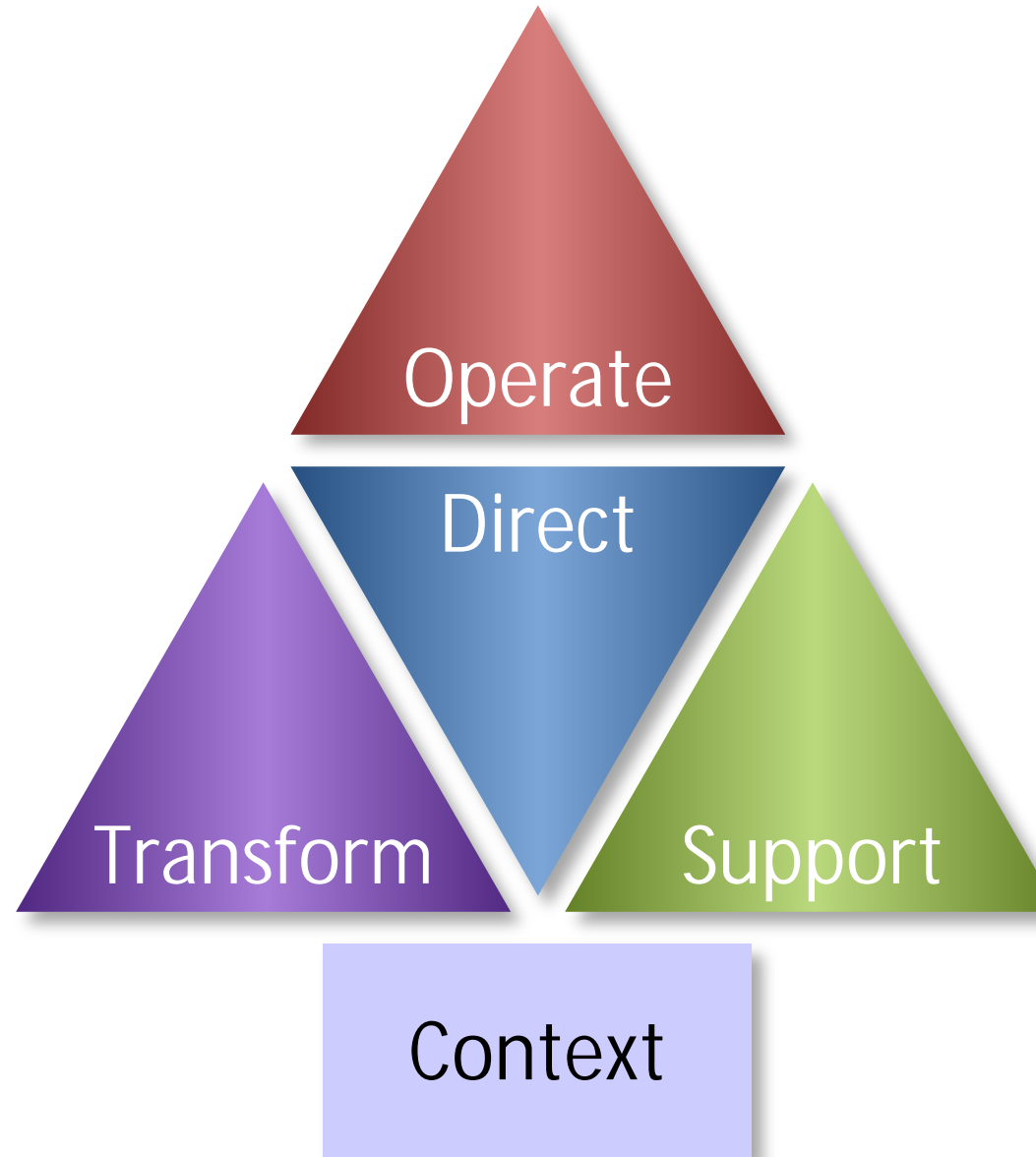

### Keypoint

Direct, Operate, Transform and Support (DOTS) is an Enterprise Ontology

### Adoption

Management: Make sure your Enterprise recognises, and connects the strategically important DOTS.





# How are the five domains of the Enterprise Ontology related?

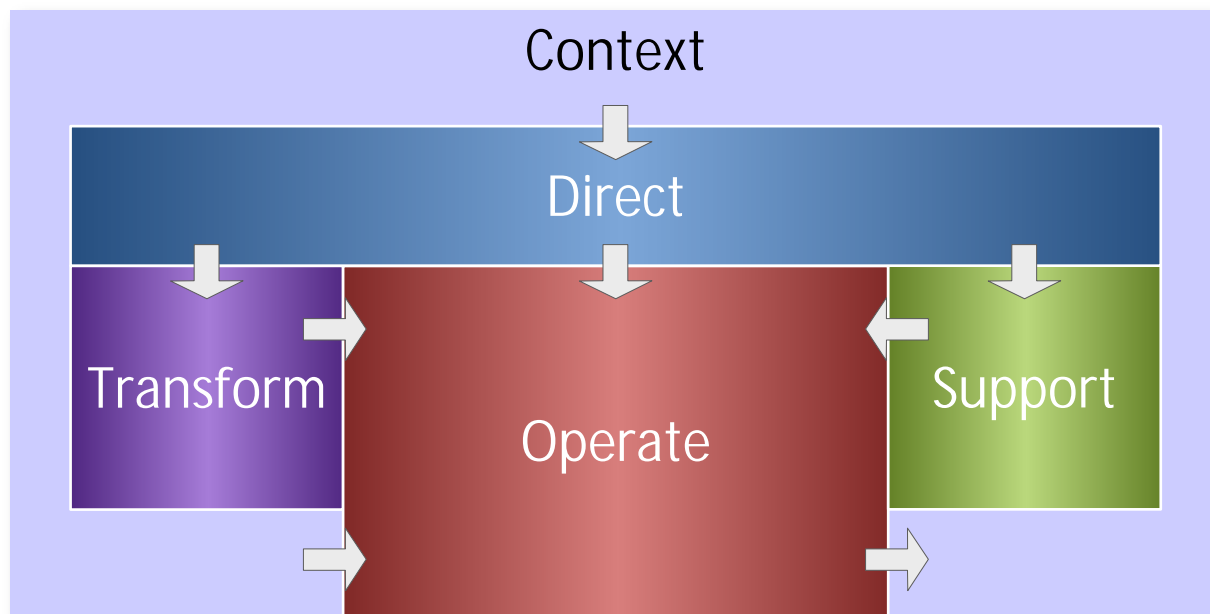
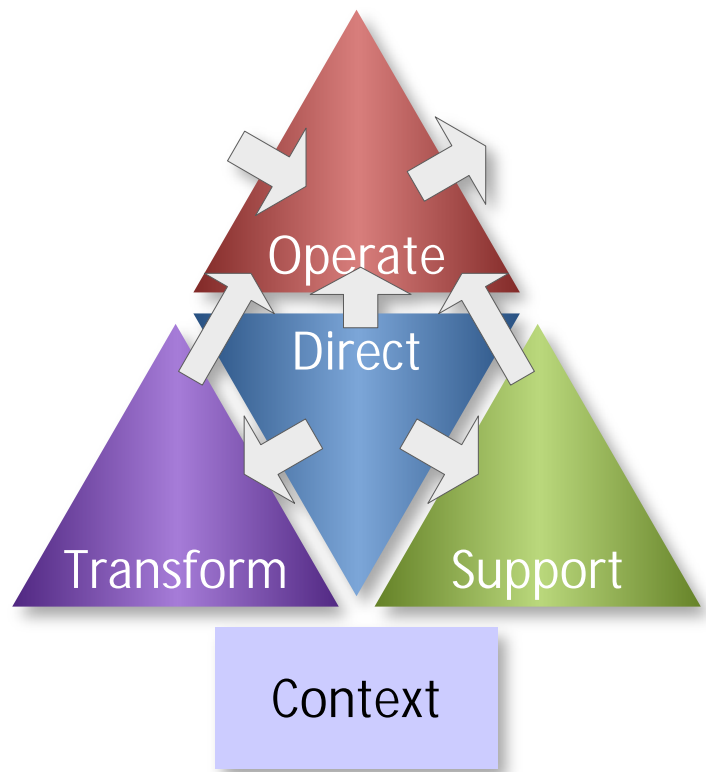

# DOTS™

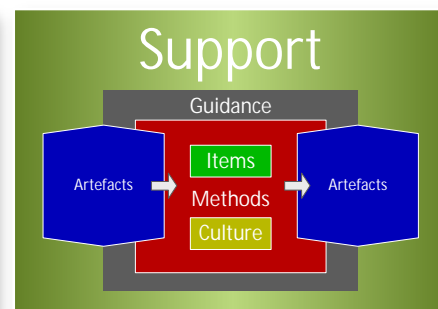
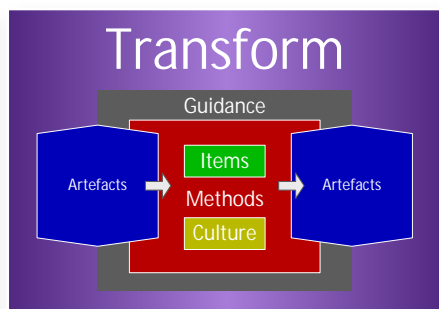
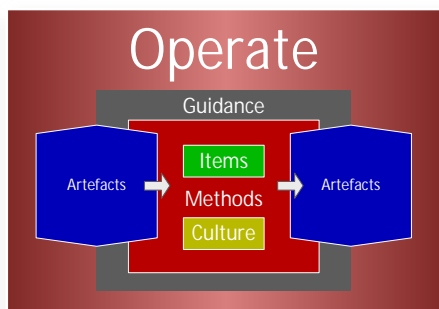
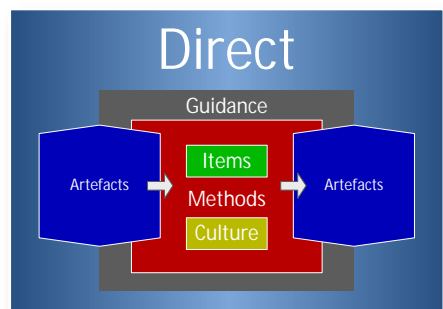

**Keypoint**  
 Direction drives Operate (supported by Transform and Support) which takes things from the Context and puts things into the context.

**Adoption**  
 Enterprise Architect:  
 Think about Enterprise Structure in terms of DOTS.

# What are some key things that Enterprises should be doing, that most are not?

## Direct

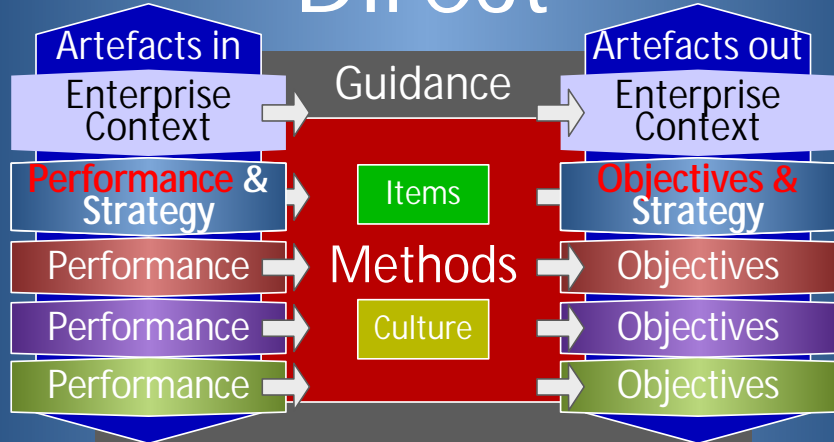

## Operate

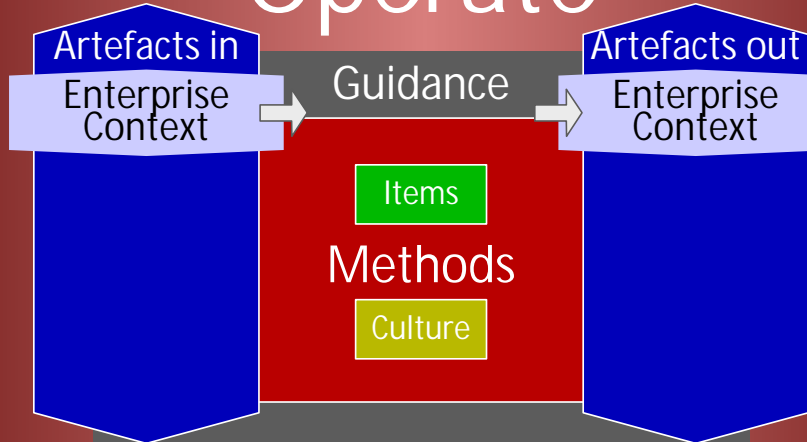

### Keypoint

There are some very key things that should be happening in all Enterprises but are not in most.

## Transform

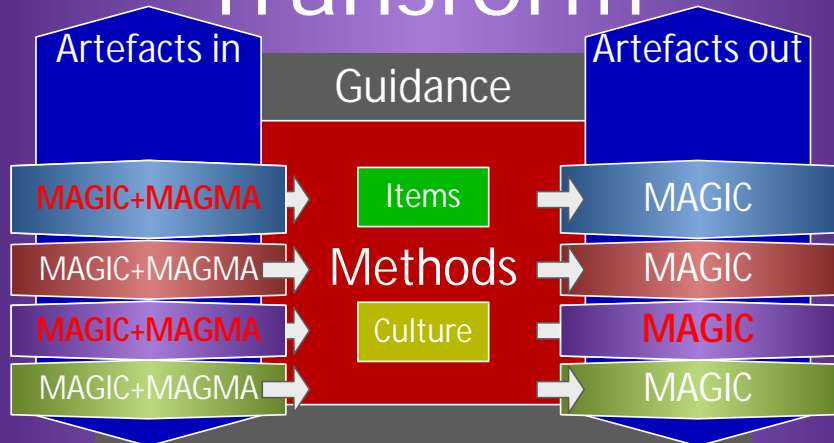

## Support

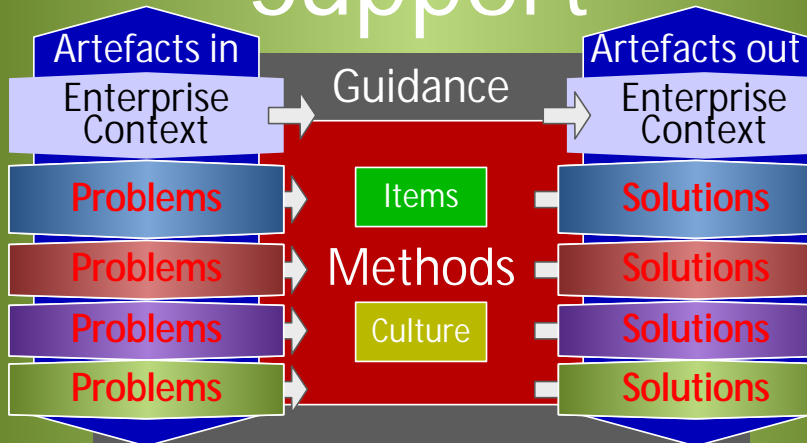

### Adoption

C-Suite: Instigate projects to assess the performance of Direct and Transformation  
 C-Suite: Instigate a project to assess the viability of extending the Support domains remit into supporting HR, Finance and Customers.

# How do the departments of most Enterprises tend to map onto the four domains of the Enterprise Ontology (DOTS)?

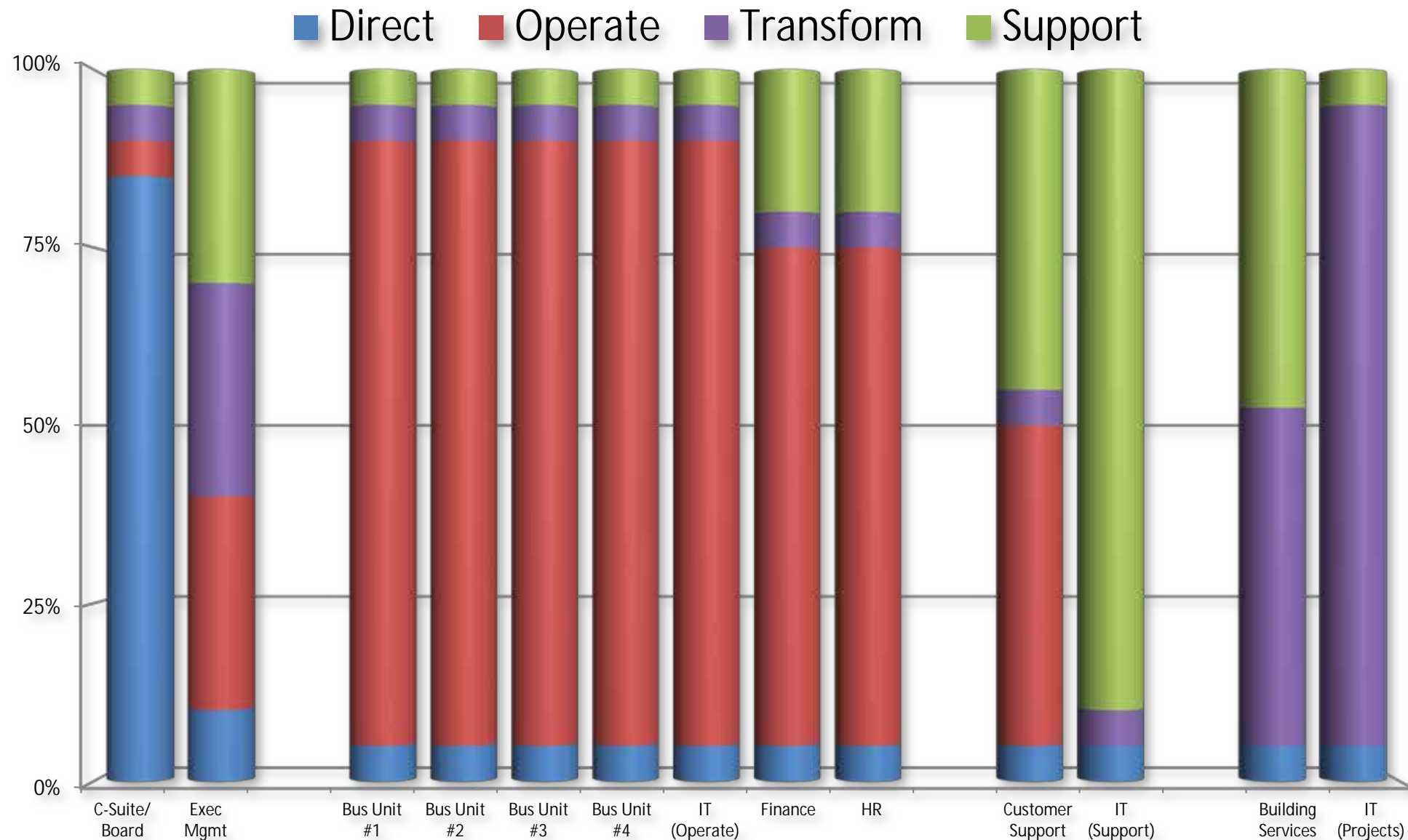

**Keypoint**  
 Fragmenting Strategically important parts of an Enterprise (DOTS), all over the Enterprise results in a Strategic loss of focus

**Adoption**  
 C-Suite: Instigate an initiative to restructure to reduce the fragmentation of DOTS.

# How should the departments of most Enterprises be organised?

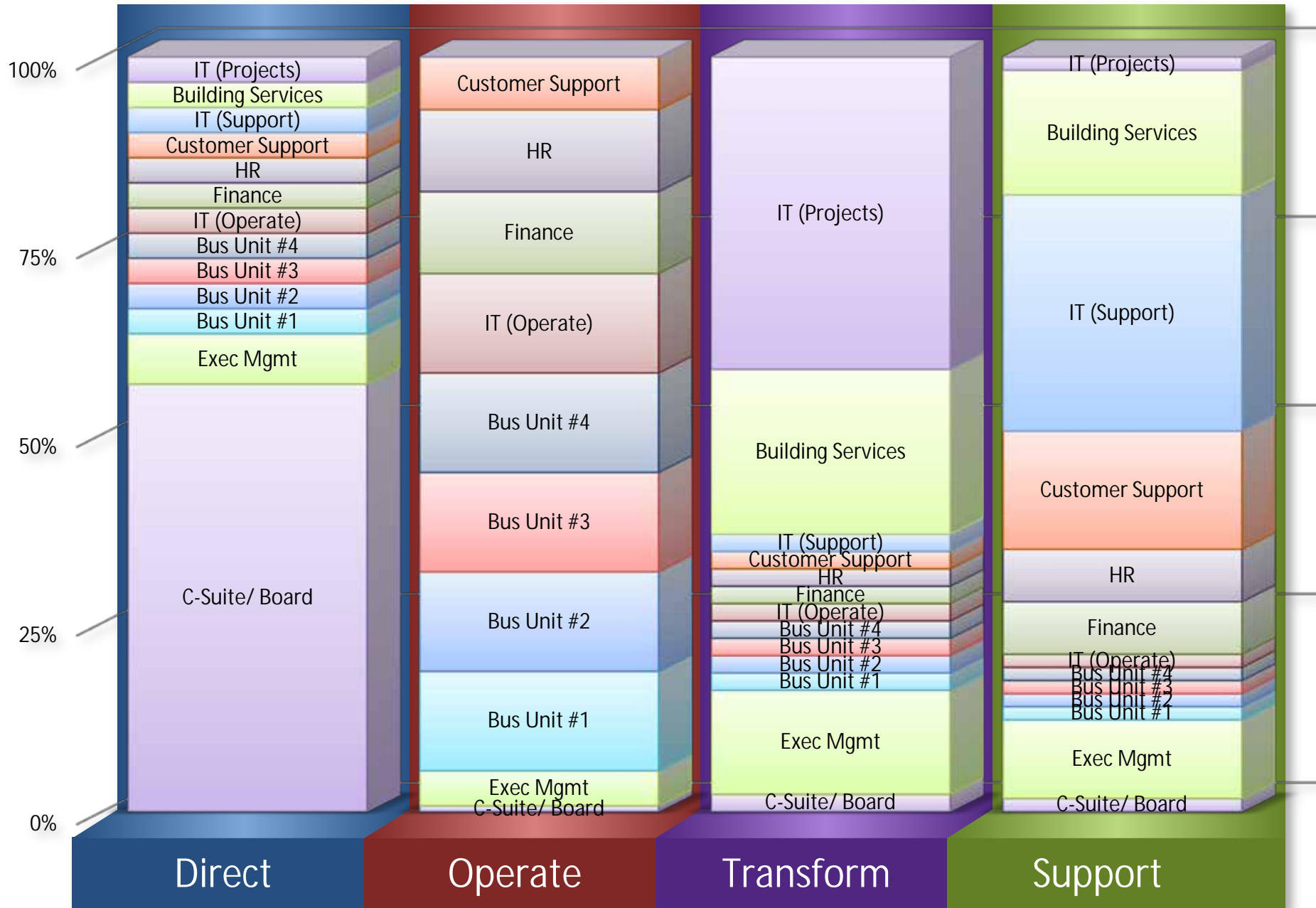

**Keypoint**  
 Grouping Strategically important parts of an Enterprise (DOTS) together, results in excellent Strategic focus

**Adoption**  
 C-Suite: Instigate an initiative to group Strategically important parts of the Enterprise (DOTS) together, to ensure a good Strategic focus.

# What does the Adoption section of PEFF contain?

# Adoption

**Keypoint**  
The Adoption section of PEFF defines the first 3 steps common to adopting any Pragmatic Framework.



# Why does Pragmatic not advocate the use of maturity models?



**Keypoint**  
**Maturity**  
**models are**  
**useful for**  
**Enterprises**  
**assessing**  
**their**  
**capabilities.**

# What is the Enterprise Transformation Maturity Canvas™ used for?



**Level 0**  
13 categories

---

<freeform>  
6 Phases

+

<freeform>  
7 Levels

**Level 1**  
62 datapoints

---

10 Metrics  
2 Phases

+

14 Metrics  
3 Levels

**Level 2**  
158 datapoints

---

10 Metrics  
6 Phases

+

14 Metrics  
7 Levels

**Level 3**  
1,880 datapoints

---

10 Metrics  
6 Phases  
15 Disciplines

+

14 Metrics  
7 Levels  
10 Categories

**Keypoint**  
The PTMC enables Transformation capability assessment, as well as post project reviews.

**Adoption**  
Management: Use the PTMC to evaluate your Transformation capability, to determine which parts needs attention.

# What tools can be used with the PTMC?



Face 2 Face

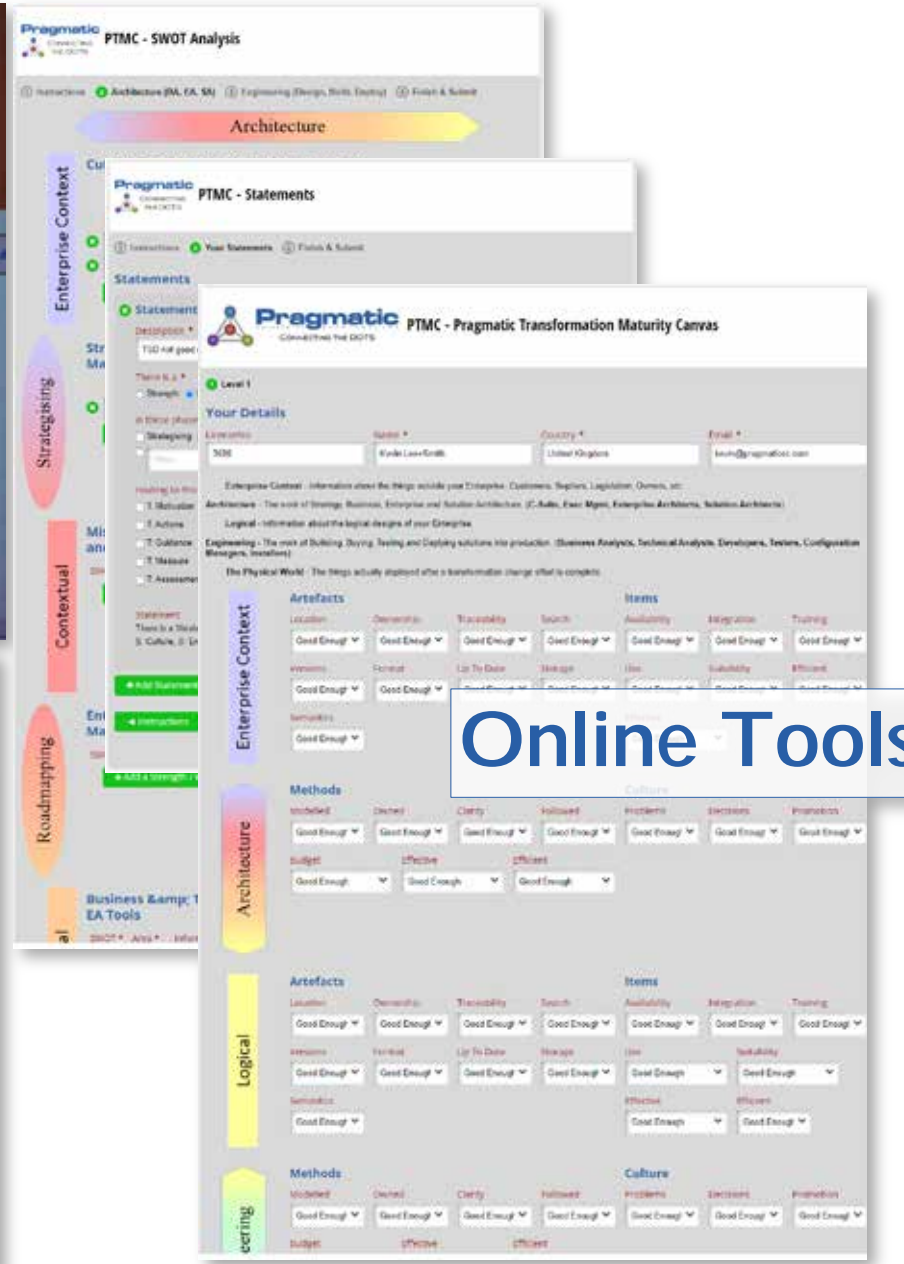

Online Tools

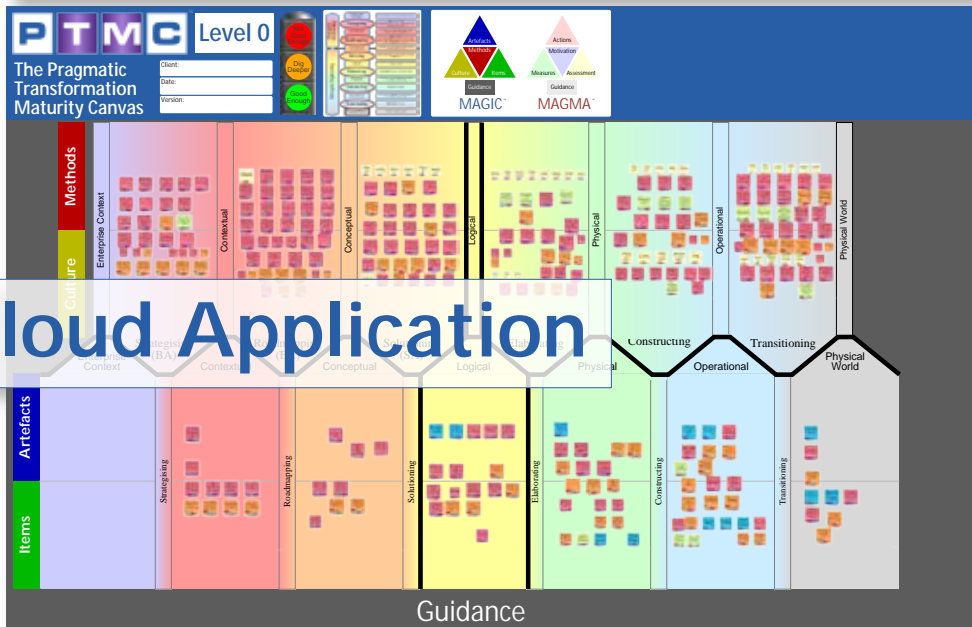

Cloud Application

**Keypoint**  
The PTMC can be populated with post-it notes, a cloud based tool or online forms.

**Adoption**  
EA Project Team:  
Use the PTMC with post-it notes, a cloud based tool or online forms.



# What is the output of the PTMC?

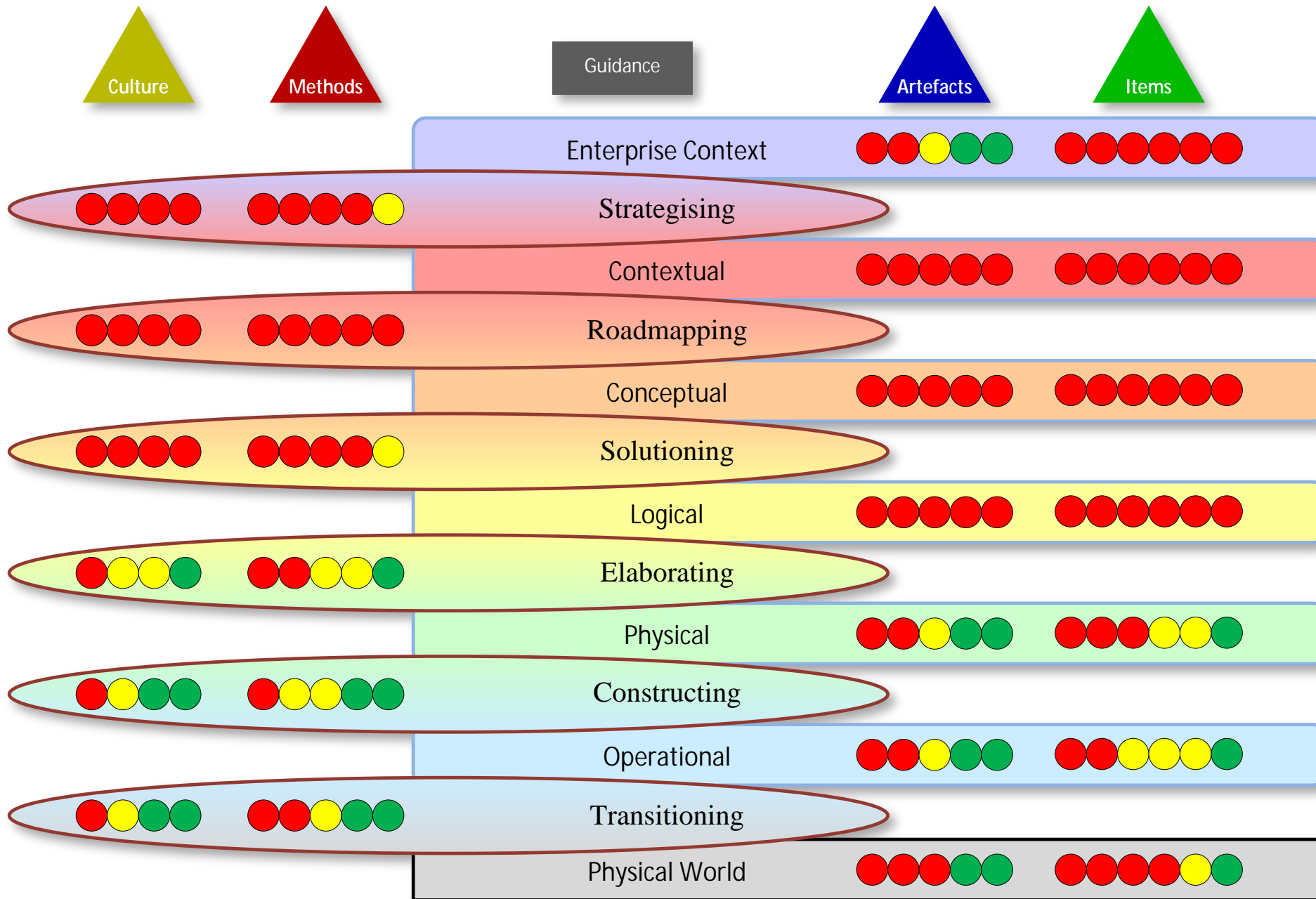

**Keypoint**  
 A PTMC report provides a high level traffic lights view of the maturity of your Enterprise Transformation Capability.



# What is the “Chasm of Procrastination”?

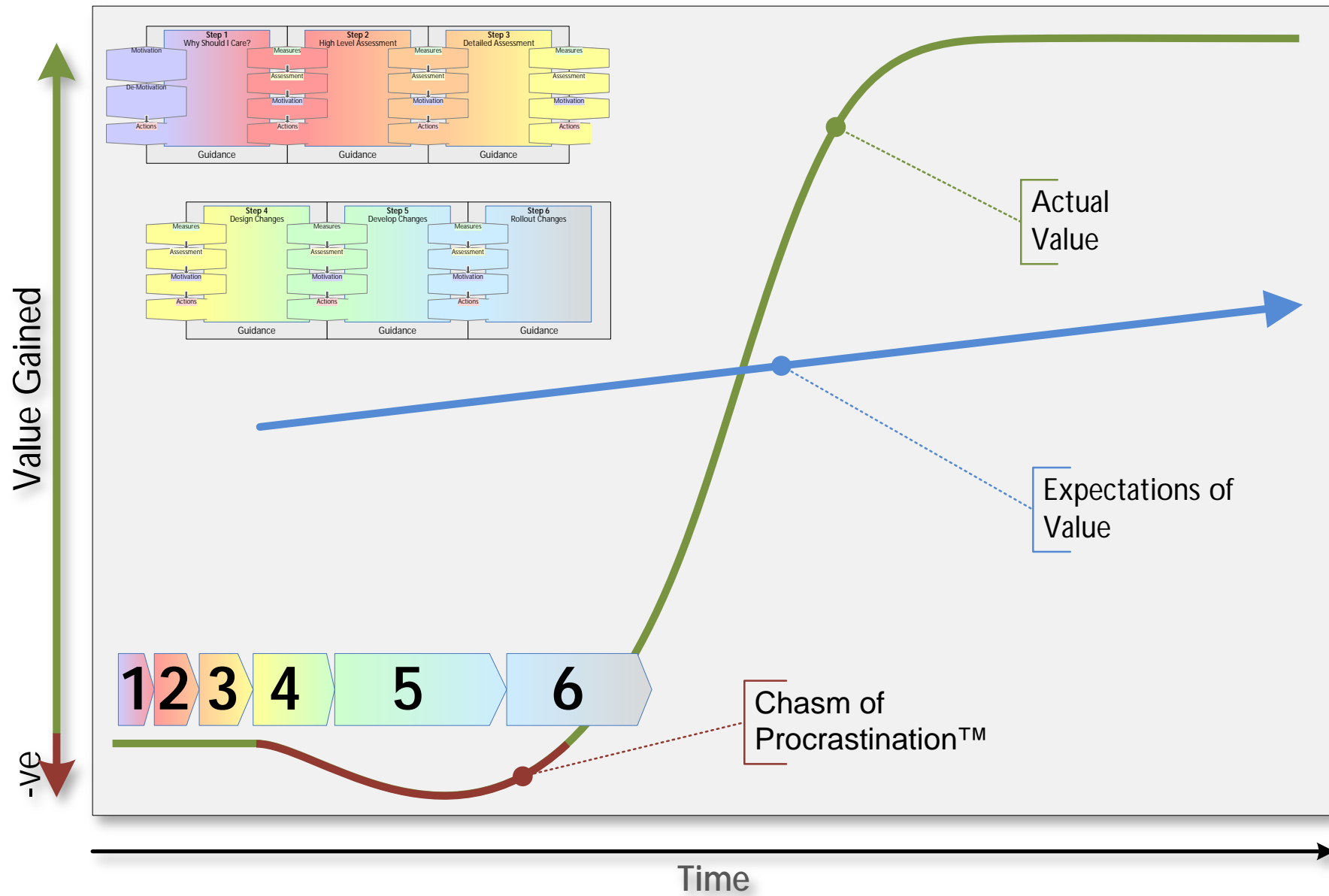

**Keypoint**  
 When adopting a Framework, value gained will always go down initially.

**Adoption Management:** When adopting a Framework, accept that the Chasm of Procrastination™ exists, and bridge it.



# What does each iteration of a framework achieve?

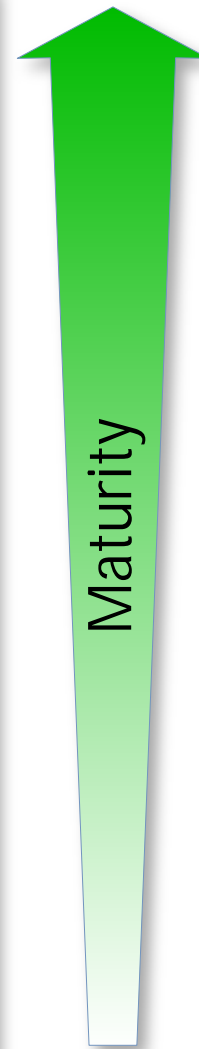
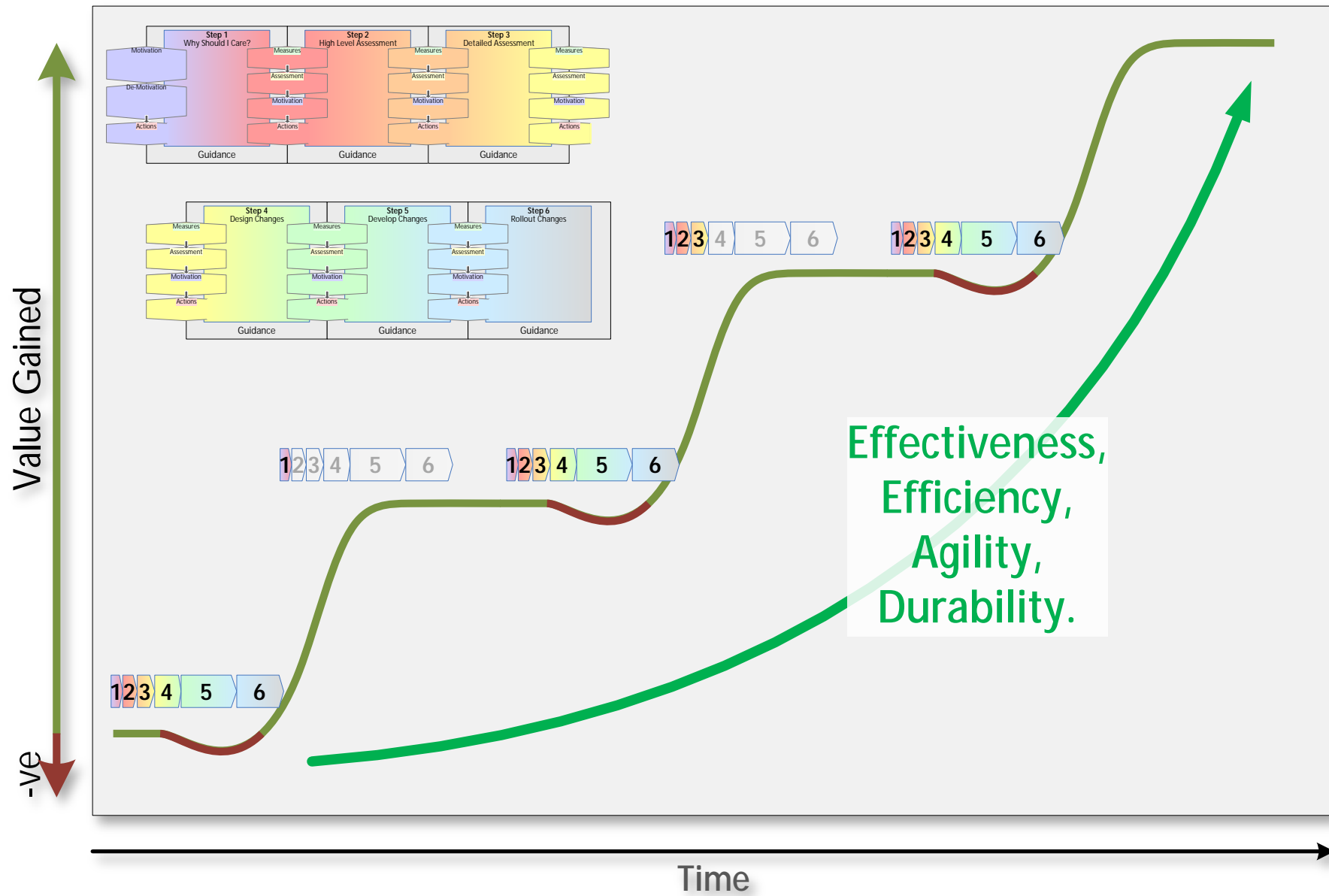

**Keypoint**  
 Use EMMA  
 to adopt  
 frameworks.

**Adoption  
 Management:**  
 Adopt Frameworks  
 iteratively, not in  
 one go.

# What are the alternate names of the phases used to adopt any Framework?

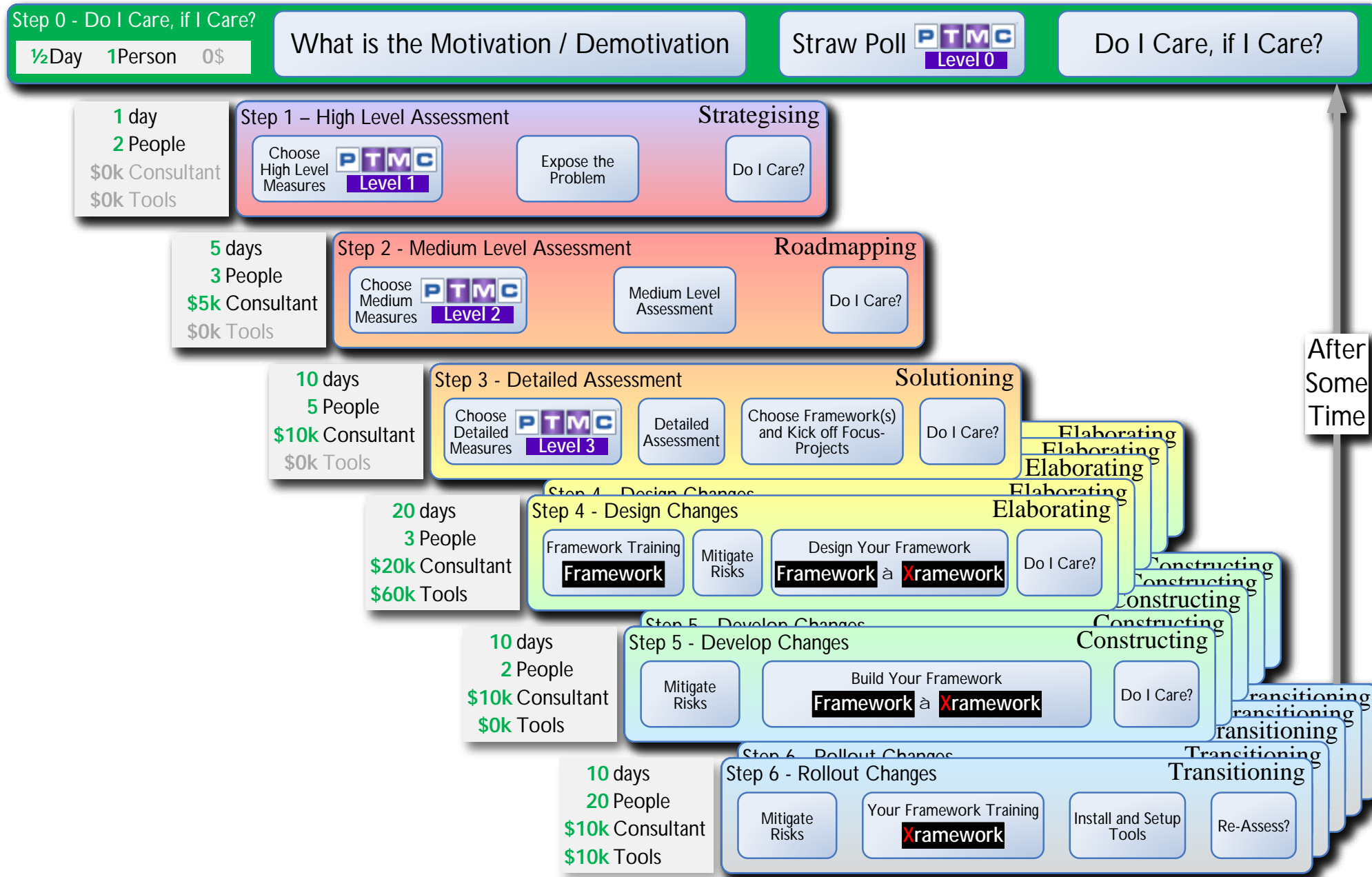

After Some Time

**Keypoint**  
 The Adoption of any Framework is a Transformation, and therefore the Phases defined in POET are used.

**Adoption**  
 C-Suite: Adopt Frameworks using the phases of Transformation defined in POET.

What happens to the Measures, Assessment and Motivation that is produced in each Adoptiopn phase is executed?

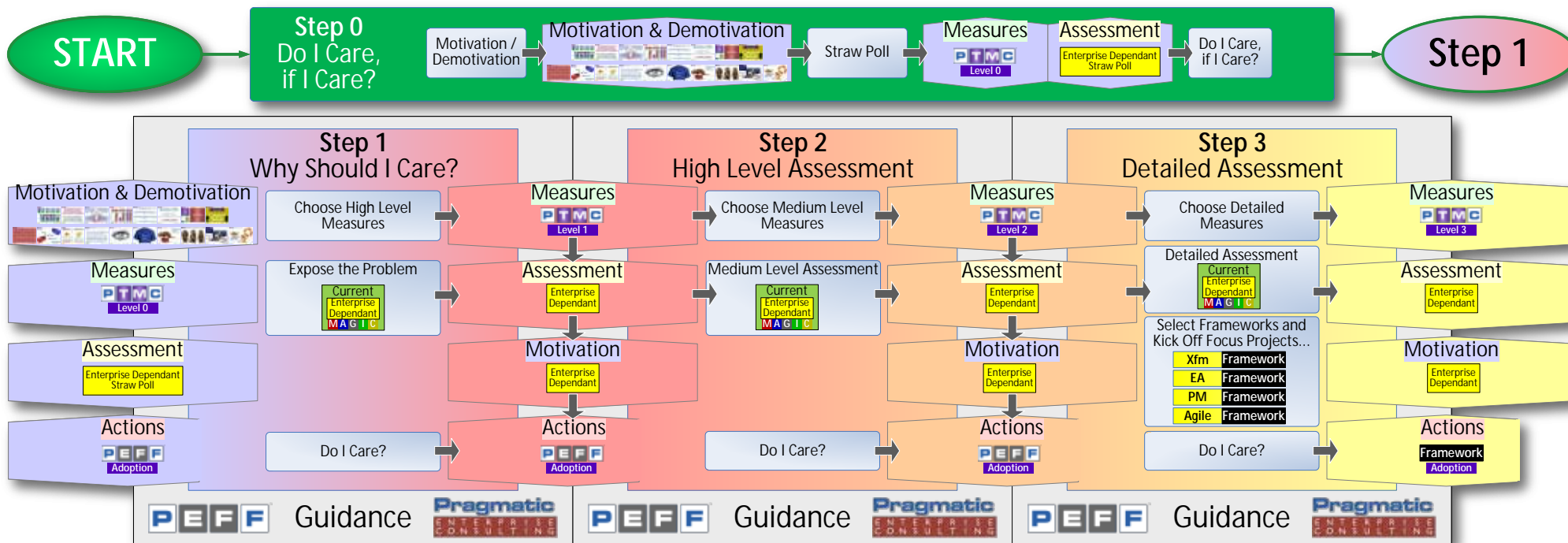

**Keypoint**  
 Adopting POET is a cascade of MAGMA which ultimately transforms the MAGIC of the Transformation Capability.

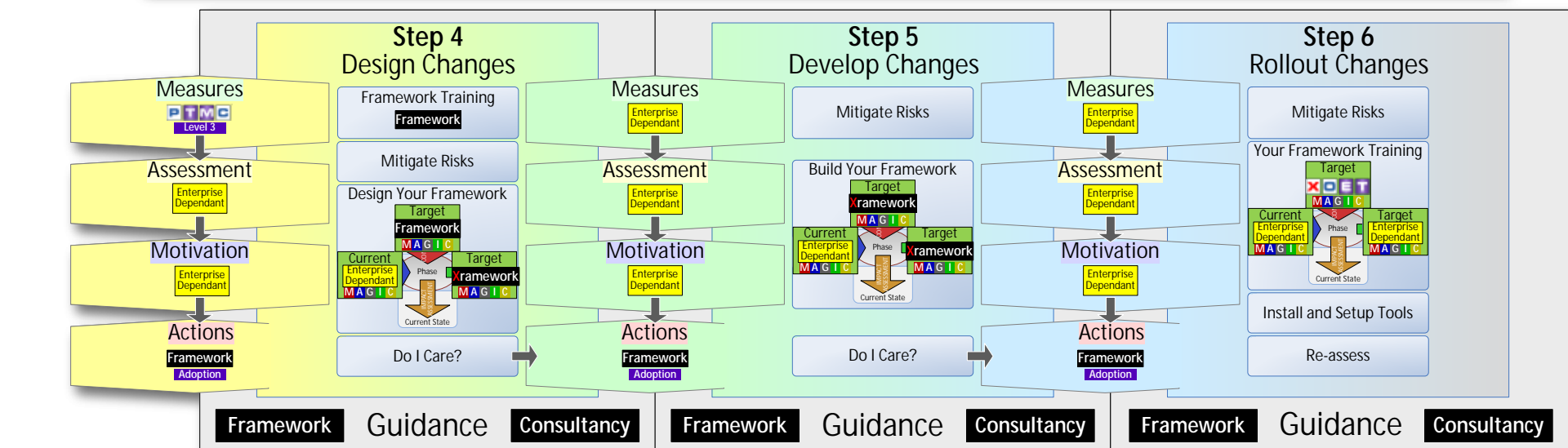

**Adoption**  
 EA Project Team: Follow the 6 steps in POET for maturing your Transformation capability.

# What is Step 0 in Adopting Pragmatics Frameworks?

Start

Step 0

Do I Care,  
if I Care?

Enterprise Context

**Keypoint**  
**EVERYTHING**  
is dependant  
upon the C-  
Suite caring  
enough.



# What is the most important step in any journey?



A journey of a thousand miles begins with a single step.

- Confucius

**Keypoint**  
The most important thing is NOT TAKING the first step. It's DECIDING to take the first step.



When Adopting and of Pragmatics Frameworks, what are the fundamental Questions that Step 0 asks?

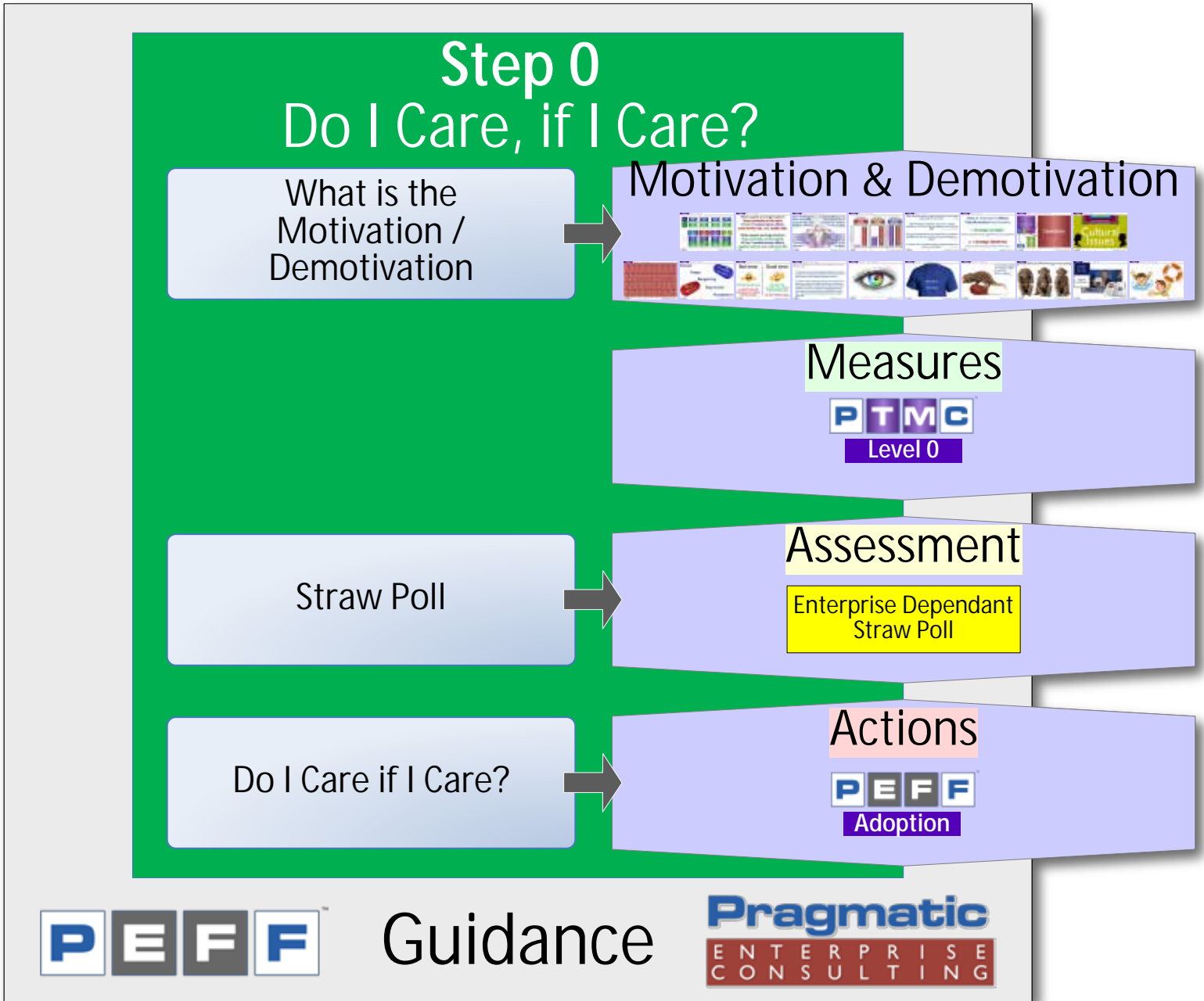

**Keypoint**  
If no one cares, there is no point in trying to use Pragmatics Frameworks to mature your Transformation Capability.

**Adoption**  
C-Suite: Use the 0th step in PEFF for maturing your Transformation capability.

# Why is the normal “Business/IT” view of a company not appropriate for the 21st Century?

Plate A – Normal View

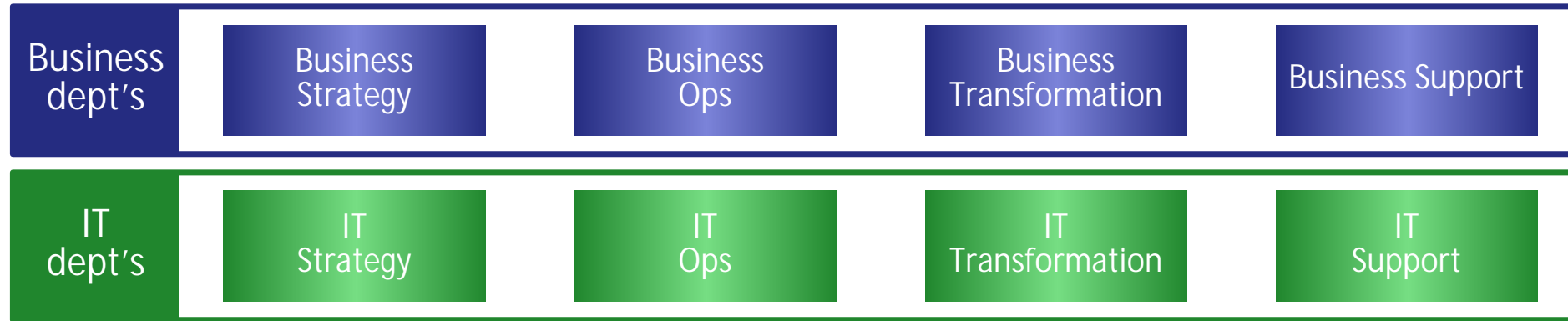

**Keypoint**  
 “The Business” and IT are so intrinsically linked, a new paradigm is needed. That paradigm is DOTS.

Plate B  
 Pragmatic View

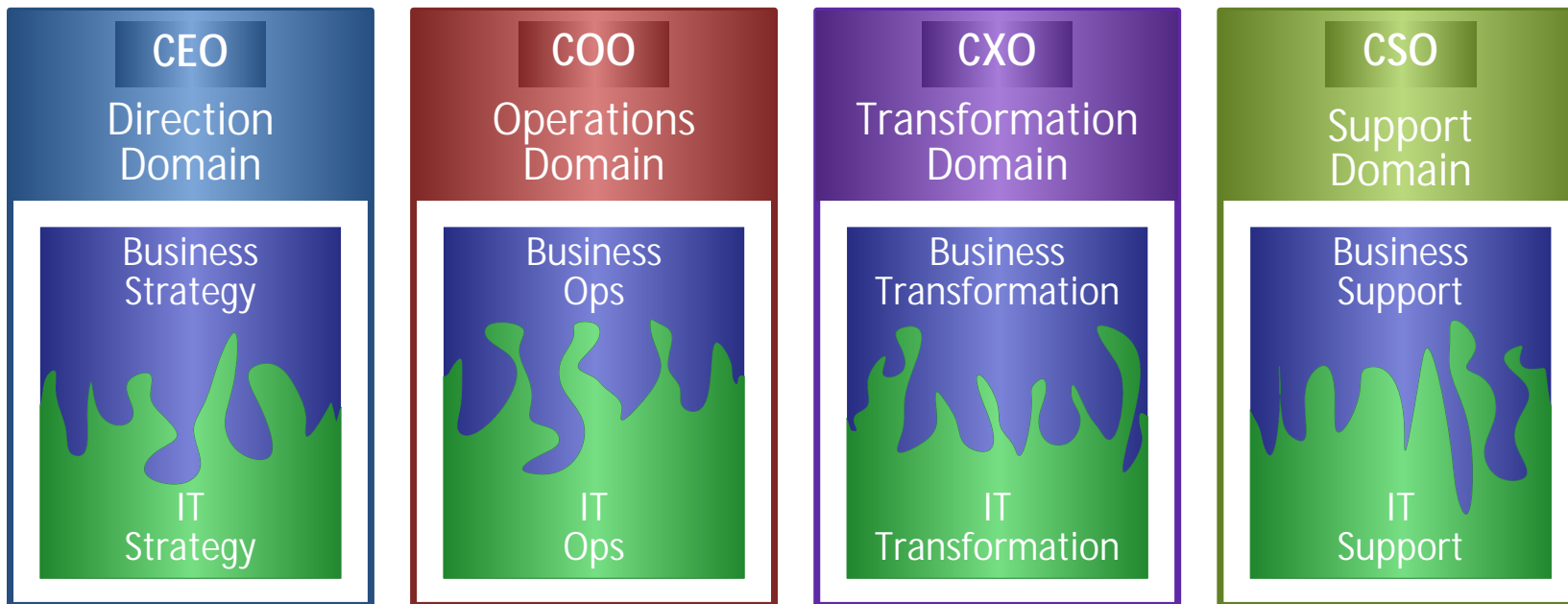

**Adoption**  
 C-Suite: Mandate the company is oriented around thinking in terms of Direction, Operation, Transformation and Support, rather than Business and IT.

# How is Deming's work related to Enterprise Transformation?

When people and organizations  
**focus primarily on the costs**  
of their Transformation efforts,  
**costs tend to rise**, and **quality falls**.

When people and organizations  
**focus primarily on the quality**  
of their Transformation efforts,  
**quality tends to rise**, and **costs fall**.

## Keypoint

We have seen  
the enemy, and  
the enemy is us  
(Management).

## Adoption

C-Suite: Mandate  
rewarding  
increasing quality,  
rather than reducing  
cost.

# What is the general percentage of the number of change initiatives that fail?

80% of PMs don't know how their projects align with business strategy.

[source: Changepoint]

Company lifespan has decreased from 67 years in the 1920s to 15 years today.

[source: Yale University]

**70% of all projects fail.**

[source: 4PM]

75% of executives believe their projects are "doomed from the start."

[source: Geneca]

17% of IT projects go so badly, they threaten the existence of the company.

[source: McKinsey]

## Keypoint

70% of all change will continue to fail, unless you change how you change.

## Adoption

C-Suite: Accept the inconvenient truth that 70% of change initiative fail.  
C-Suite: Mandate the use of the PTMC to find out what's wrong in your Enterprise.





# What are the 3 eras of Enterprise Viability?

19<sup>th</sup> Century

**What you do.**

Operations

20<sup>th</sup> Century

**How you do, what you do.**

the Transformation of Operations

21<sup>st</sup> Century

**How you change, how you do, what you do.**

the Transformation of Transformation

**Keypoint**  
It's not what you do, it's the way that you do it. (And that's what gets results.)

**Adoption**  
C-Suite: Agree that we are living in the era of the Transformation of Transformation.

Capability Importance ↑

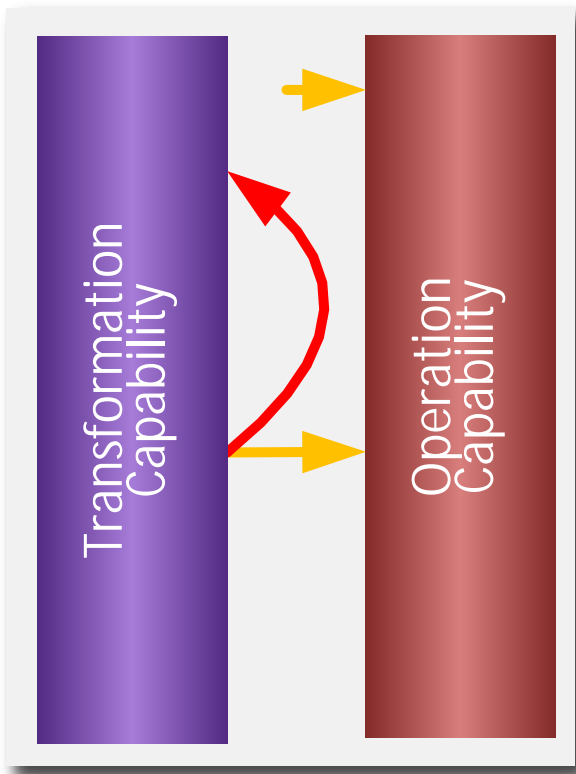
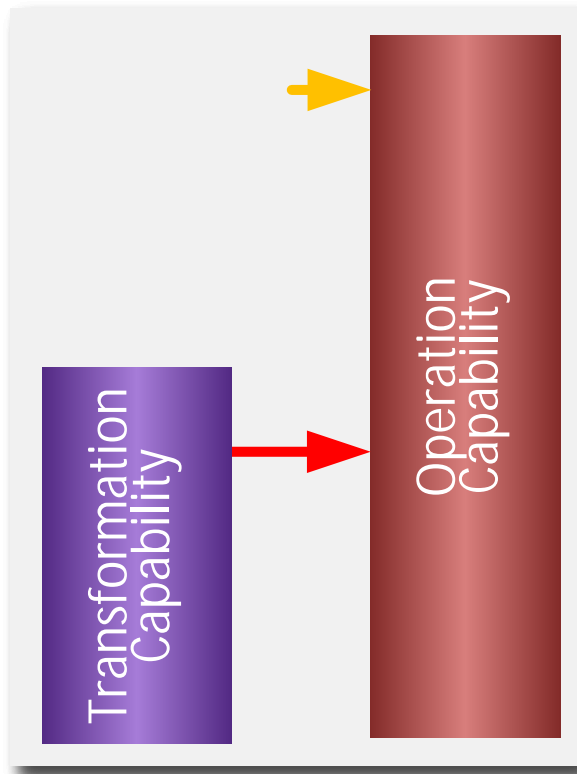
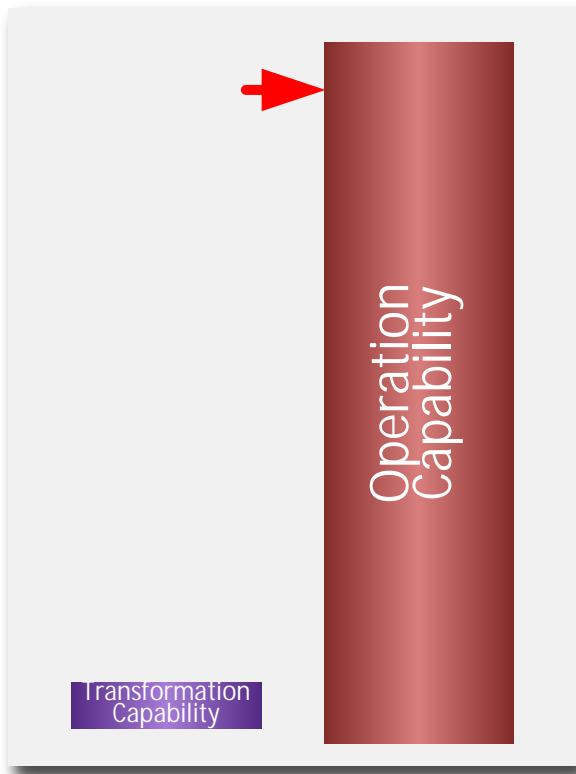



**BREAK!**

**Back at 14:43**



What are the “Sage Words” that push us to want to look at and mature the Transformation domain?

*“If the rate of change on the outside exceeds the rate of change on the inside, the end is near.”*

- Jack Welch

*“Digital disruption is the main reason just over half the companies on the Fortune 500 have disappeared since the Year 2000”*

- Pierre Nanterme | CEO Accenture

*“It is not the strongest of the species that survives, nor the most intelligent that survives, it is the one that is most adaptable to change.”*

- Charles Darwin

*“We cannot solve our problems with the same thinking we used when we created them.”*

- Albert Einstein

**Keypoint**  
Jack Welch,  
Darwin and  
Einstein do have  
a point!

**Adoption**  
C-Suite: Agree that  
Operations can only  
flourish, if  
Transformation  
enables it.



What is the basic premise that the C-Suite need to agree with, before they spend any energy evaluating and maturing their Transformation capability?

# How an Enterprise effects Transformation has become a Strategic Strength

where massive business opportunities can be gained,

# or a Strategic Weakness

where massive business problems will result.

## Keypoint

How an Enterprise effects Transformation is becoming a Strategic Strength or a Strategic Weakness.

## Adoption

C-Suite: Agree that HOW the Enterprise effects Transformation is A) a Strategic Strength or B) a Strategic Weakness.

# Why is it difficult for people to "see" the Transformation domain?

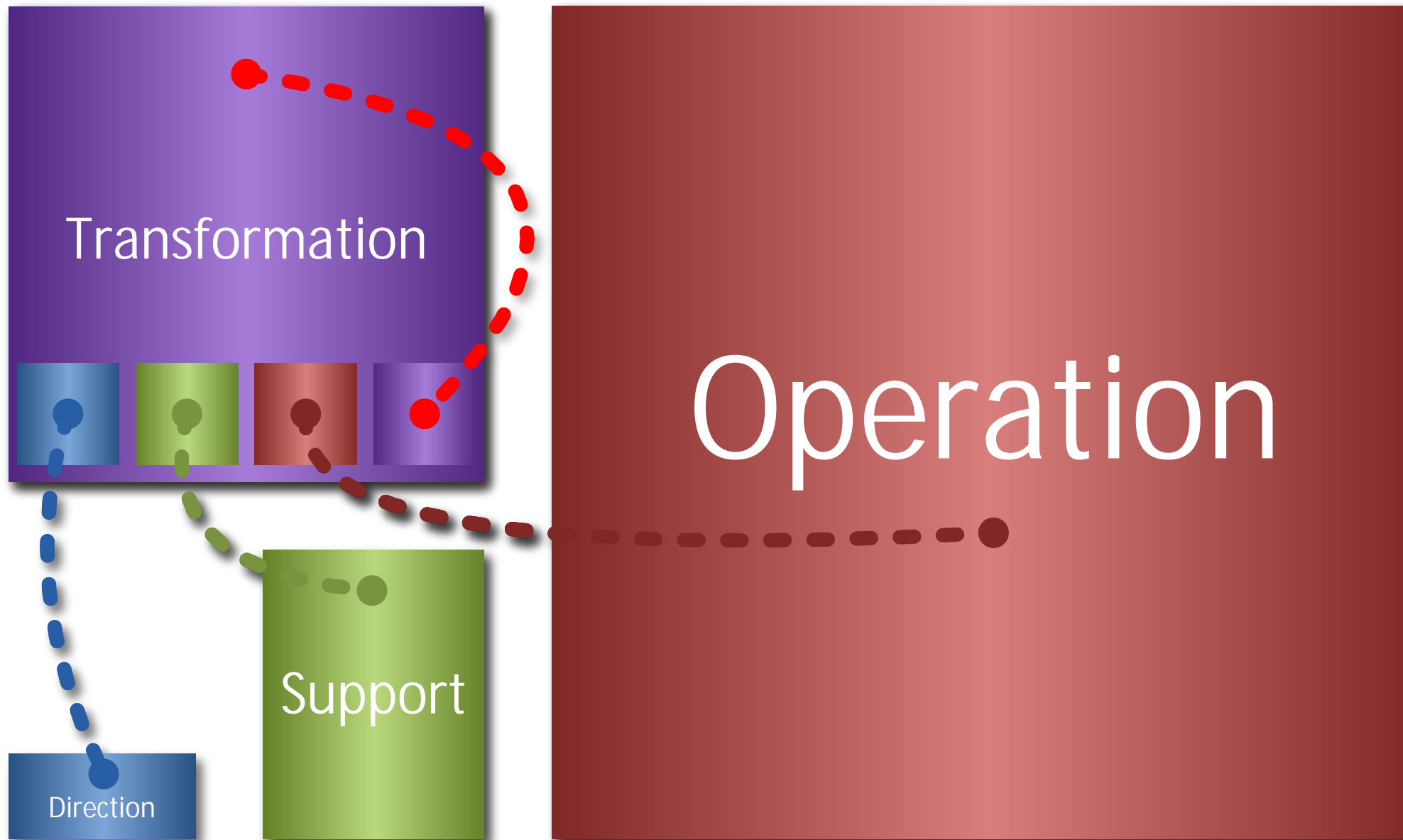

## Keypoint

The Transformation of Transformation (ToT) is using a Transformation capability, to mature a Transformation capability.

## Adoption

Management: Allocate some resource to the Transformation of Transformation (ToT).

What are some general issues that could motivate Enterprises to increase the maturity of the Culture they use for Enterprise Transformation?

Technology Issues (Items)

Documentation Issues (Artefacts)

Process Issues (Methods)

Principles Issues (Guidance)

# Cultural Issues



## Keypoint

The Problems you face or Opportunities you wish to exploit, with respect to the Culture, drive the changes you need to make.

## Adoption

EA Project Team: Define the Problems you face or the Opportunities you wish to exploit, with respect to the Culture used for Transformation.



# What should you use to take a broad temperature of an Enterprise's Transformation Capability?

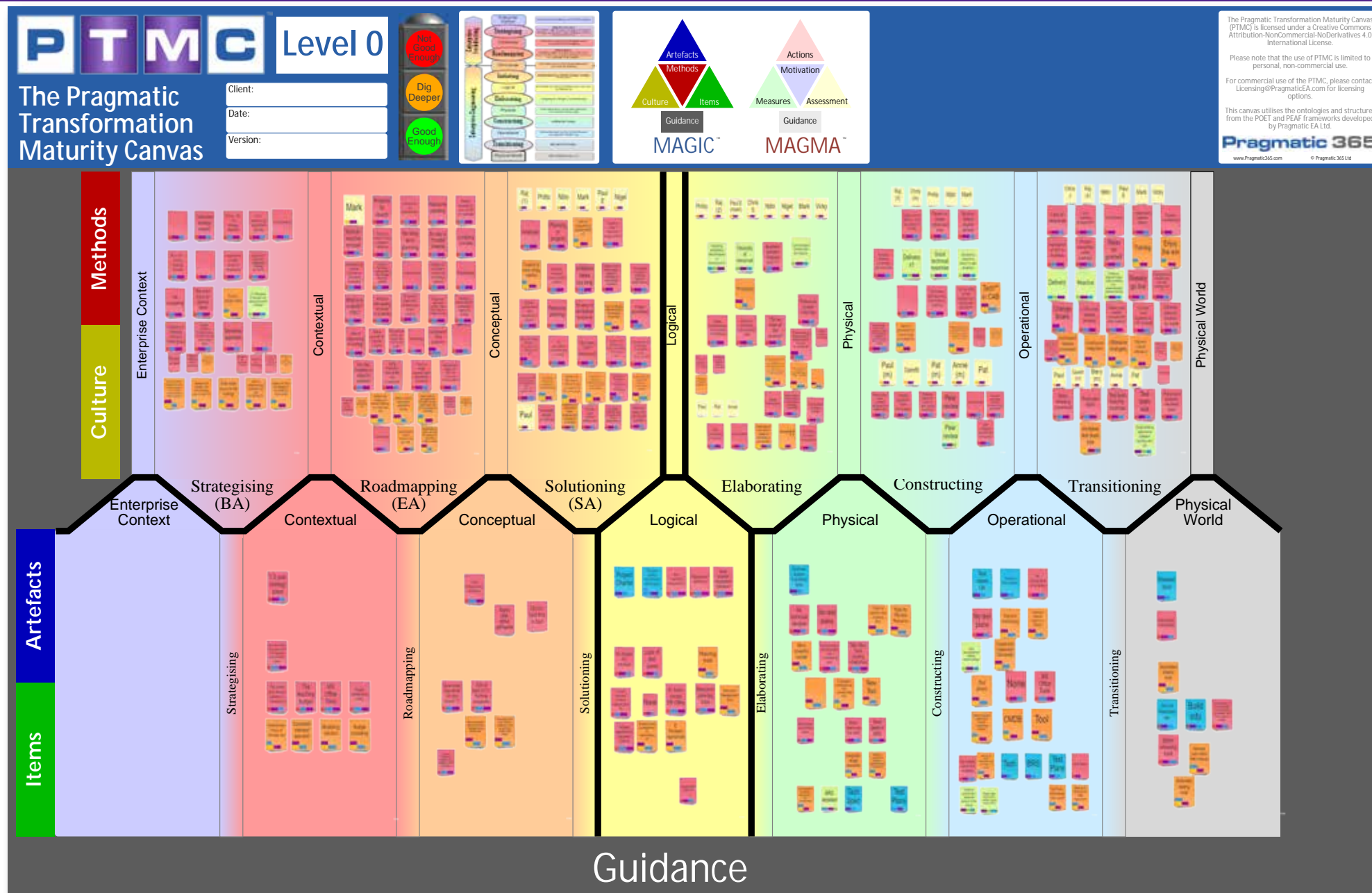

**Keypoint**  
 Use PTMC Level 0 to conduct a free flowing gathering of ideas.

**Adoption**  
 C-Suite: Instigate an initiative to use the Level 0 PTMC to take the temperature of the Enterprise's Transformation Capability.

# What is Domain Blindness (in relation to a barrier to adoption)?



## Keypoint

PEFF/POET/PEAF don't replace what you do. They make the MAGIC your do more Effective, Efficient, Agile and Sustainable.

## Adoption

C-Suite: Engage Pragmatic to understand how they can increase the Effectiveness, Efficiency, Agility and Sustainability of your Transformation Capability.



# What is Domain Blindness (in relation to a barrier to adoption)?

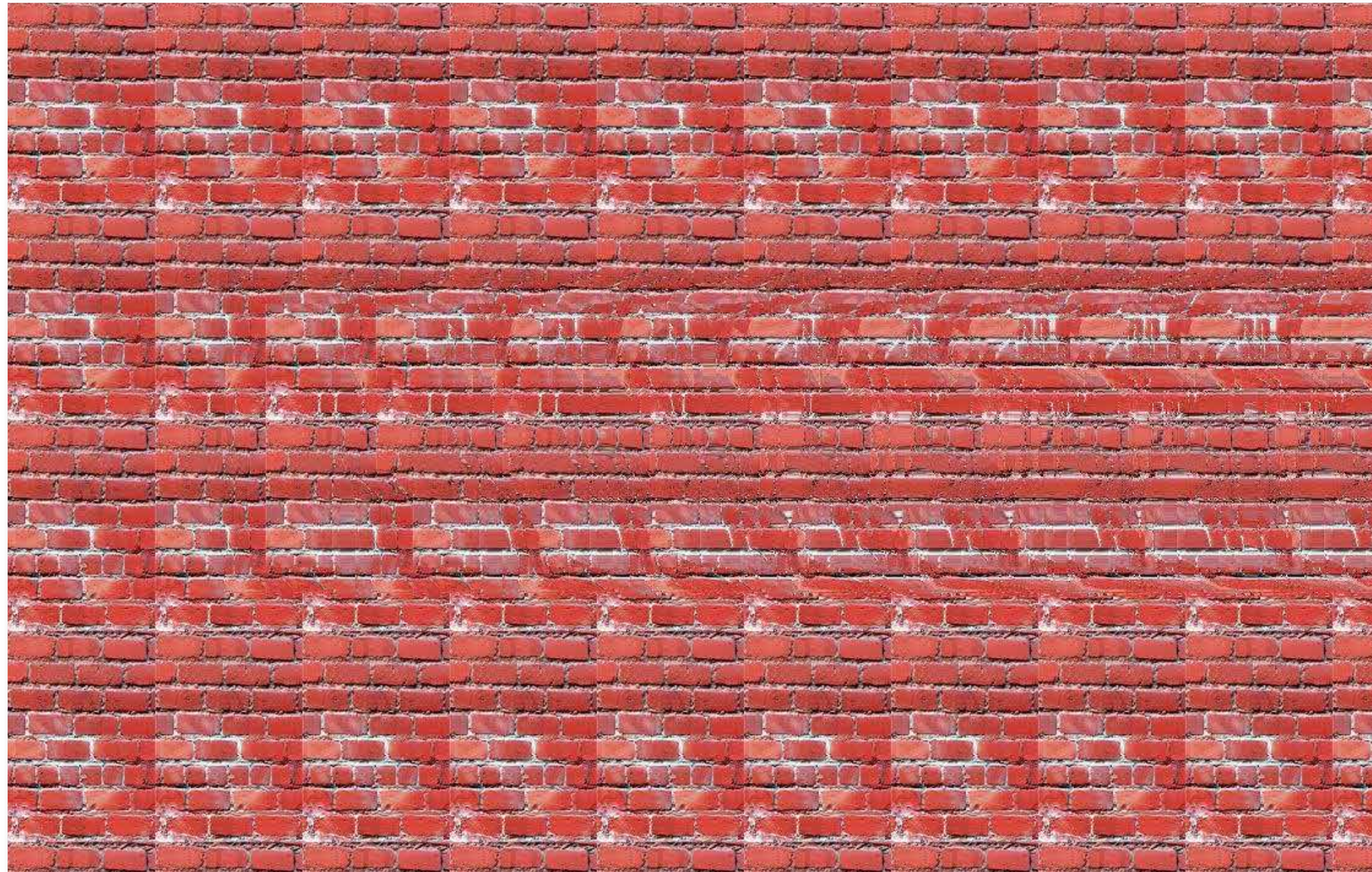

## Keypoint

Domain Blindness:  
People simply  
cannot see the  
Transformation  
domain.

## Adoption

C-Suite: Engage  
Pragmatic to  
enable people to  
see.



# What is the Red Pill (in relation to a barrier to adoption)?

Denial

Anger

Bargaining

Depression

Acceptance



## Keypoint

Red Pill:

If you do not want to swallow the Red Pill, no one will force you

## Adoption

C-Suite: Engage Pragmatic to give you the Red Pill. (But only you can decide to take it).

# What is the Timing Paradox (in relation to a barrier to adoption)?

## Bad Times



We feel the pain but,

we don't have the resources or mandate.

## Good Times



We have the resources and can create the mandate but,

we don't feel the pain.

### Keypoint

Timing Paradox:  
When maturation is needed, there are no resources to effect the change. When there are resources to effect the change, there is no requirement to do so.

### Adoption

C-Suite: When times are good, call for the maturation of the Transformation Capability.





# What is the Management/Workers Paradox (in relation to a barrier to adoption)?

## Workers



We feel the pain but,

we don't have the resources or mandate.

## Management



We have the resources and can create the mandate but,

we won't admit there is any pain.

### Keypoint

Management/Workers Paradox:

Workers experience the problems on a daily basis. Management says there are no problems,

### Adoption

Management: Start actively listening to the workers, and use the PTMC to perform an assessment

# What is the Process Paradox (in relation to a barrier to adoption)?

Martin Brundle commenting on how the strategy and planning of F1 is a mess...

“The system is broken and it needs changing, but to make changes you've got to get through the broken system, so it's spinning its wheels and going absolutely nowhere.

It's going to take a big bang to change it because between them they couldn't run a bath to be honest, and there's no way that they'll find a way and have a common sense pill and get on with it. So, until there's a big bang (and then you've got to be concerned about what fills the vacuum) that's when it will move forward and I don't know when that will be.”

## Keypoint

**Process Paradox:**  
To get the change on the radar, we are battling against the currently flawed process. If the current process was not flawed, we would not need to mature it.

## Adoption

**Management:** Use POETs Transformation Process, when adopting POET or PEAFF.



# What is Unconscious Degradation (in relation to a barrier to adoption)?



## Keypoint

Unconscious Degradation: The Effectiveness, Efficiency, Agility and Durability of a Transformation capability degrades slowly over time, and therefore can be easily missed.

## Adoption

C-Suite: Instigate an initiative to perform a Transformation eye test.





# What is False Accomplishment (in relation to a barrier to adoption)?

## Keypoint

False Accomplishment: Many Enterprises think they have already “done” some kind of maturation when in fact they have not.

## Adoption

C-Suite: Admit that EA adoption needs more work.



# What is Oversimplification (in relation to a barrier to adoption)?

*“Everything should be made as simple as possible.  
But no simpler.”*

- Einstein

## Keypoint

Oversimplification: Many Enterprises have a compulsion to reduce things to the point of uselessness.

## Adoption

Management: Don't dilute POET/PEAF to the point of uselessness.

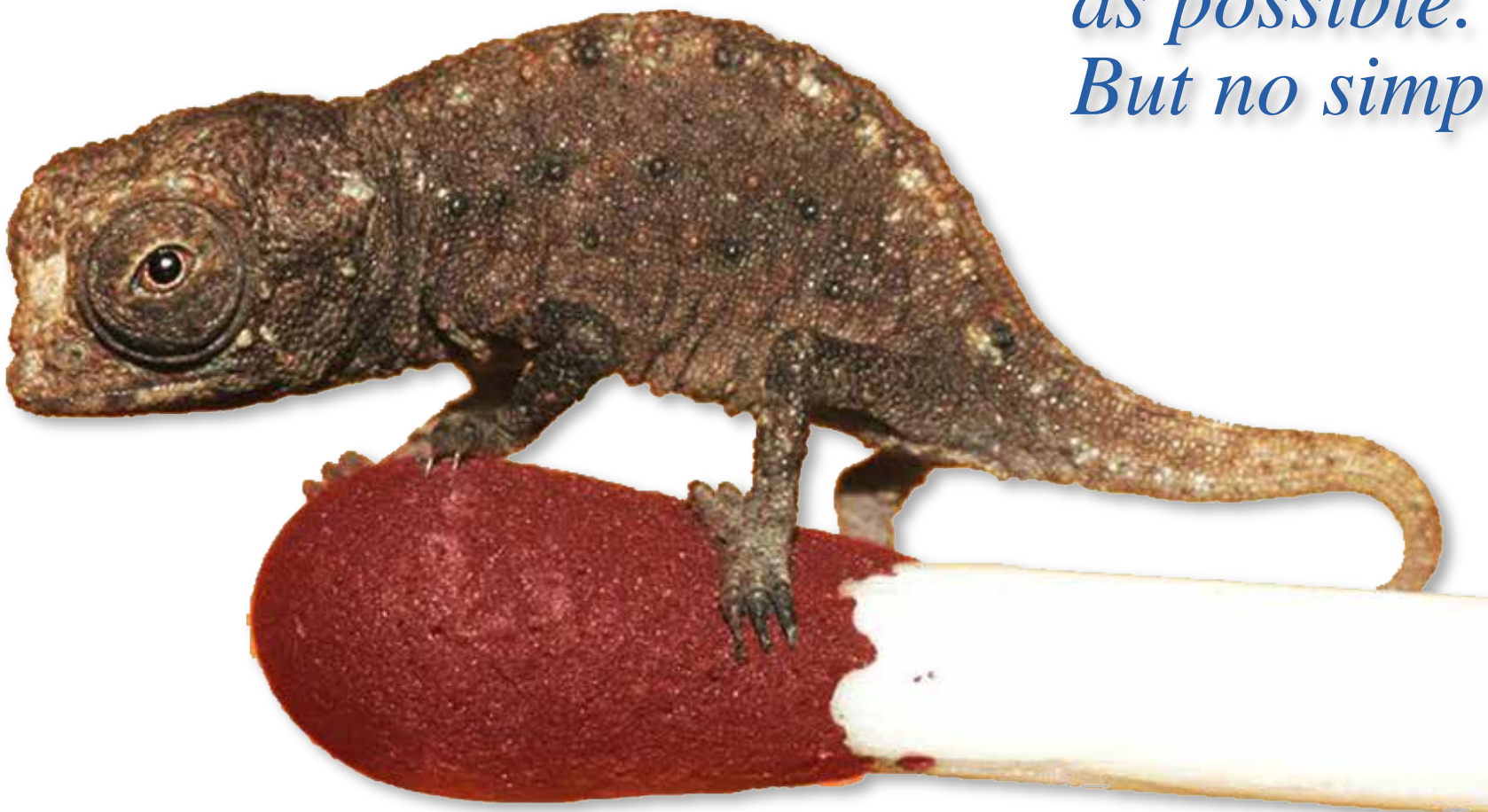



# What is Reality Avoidance (in relation to a barrier to adoption)?

Internal

External



Kikazaru



Mizaru



Iwazaru

## Keypoint

Reality Avoidance:  
Many Enterprises do not want to hear that their Transformation Capability has serious problems, and many Consultancies do not want to tell them.

## Adoption

C-Suite: Admit the Transformation Capability has serious flaws.



# What is Not Being Sexy (in relation to a barrier to adoption)?

HILLARY  
ROTTEN  
CLINTON

WHAT  
HAPPENED

Kevin Lee Smith



## Keypoint

It's Just Not Sexy:  
Many Enterprises are not interested in maturing their Transformation Capability because it's just not "sexy".

## Adoption

C-Suite: Don't adopt POET or PEAFF because they are the latest buzzword's. Adopt them because they provide value.



# What is Saving the Drowning Children (in relation to a barrier to adoption)?

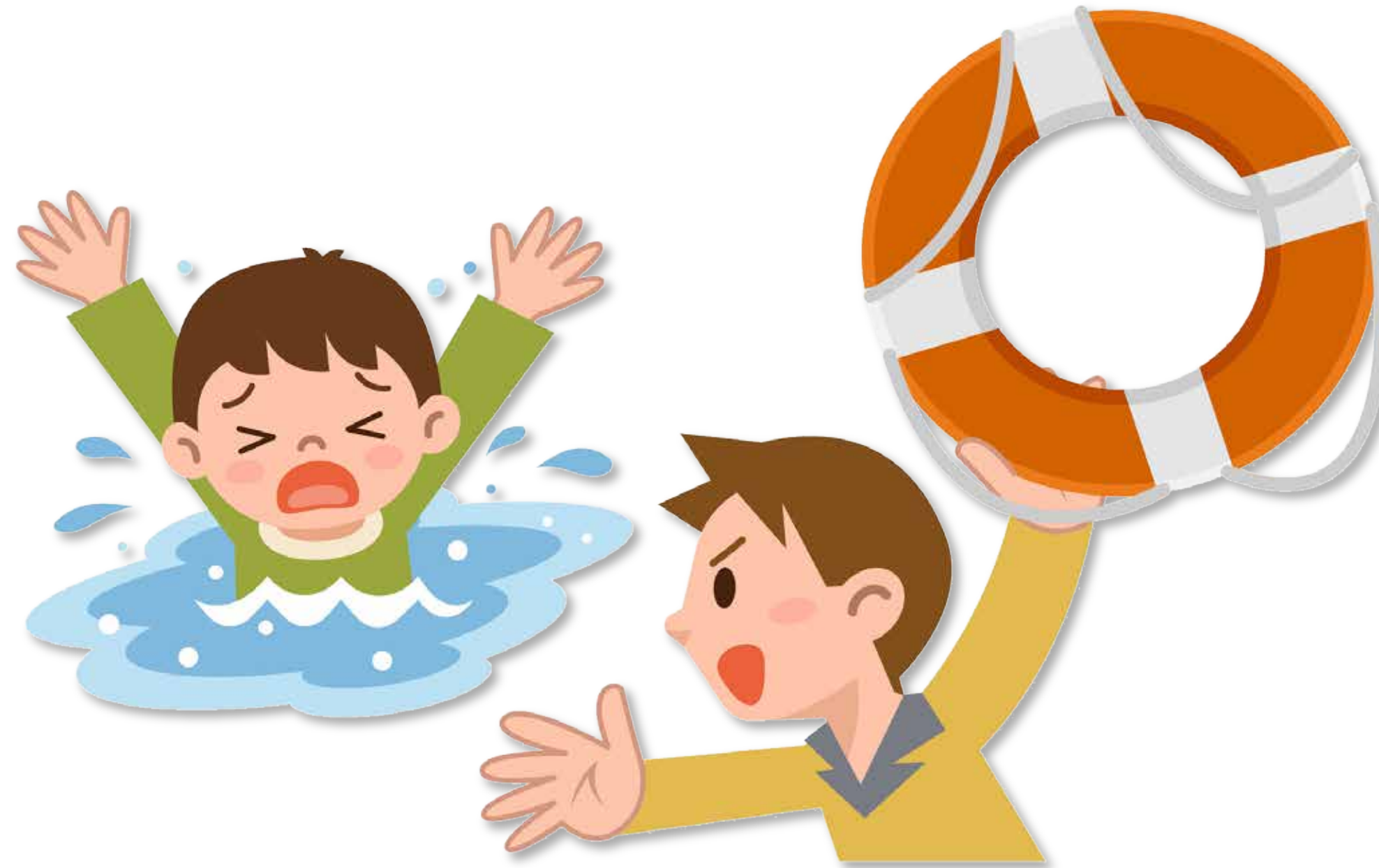

## Keypoint

Fix the Fundamentals:  
Don't spend all your time saving drowning children. Spend some of your time preventing them from falling into the river as well.

**Adoption Management:** Allow people to concentrate on fixing fundamentals problems.

# What is the first step in Adopting Pragmatics Frameworks?

Strategising

Enterprise Context

**Step 1**  
**High Level**  
**Assessment**

Contextual

**Keypoint**  
A quick and  
dirty  
evaluation will  
tell you  
enough, for  
you to decide  
if you want to  
proceed.





# When Adopting any of Pragmatics Frameworks, what are the fundamental Actions in Step 1?

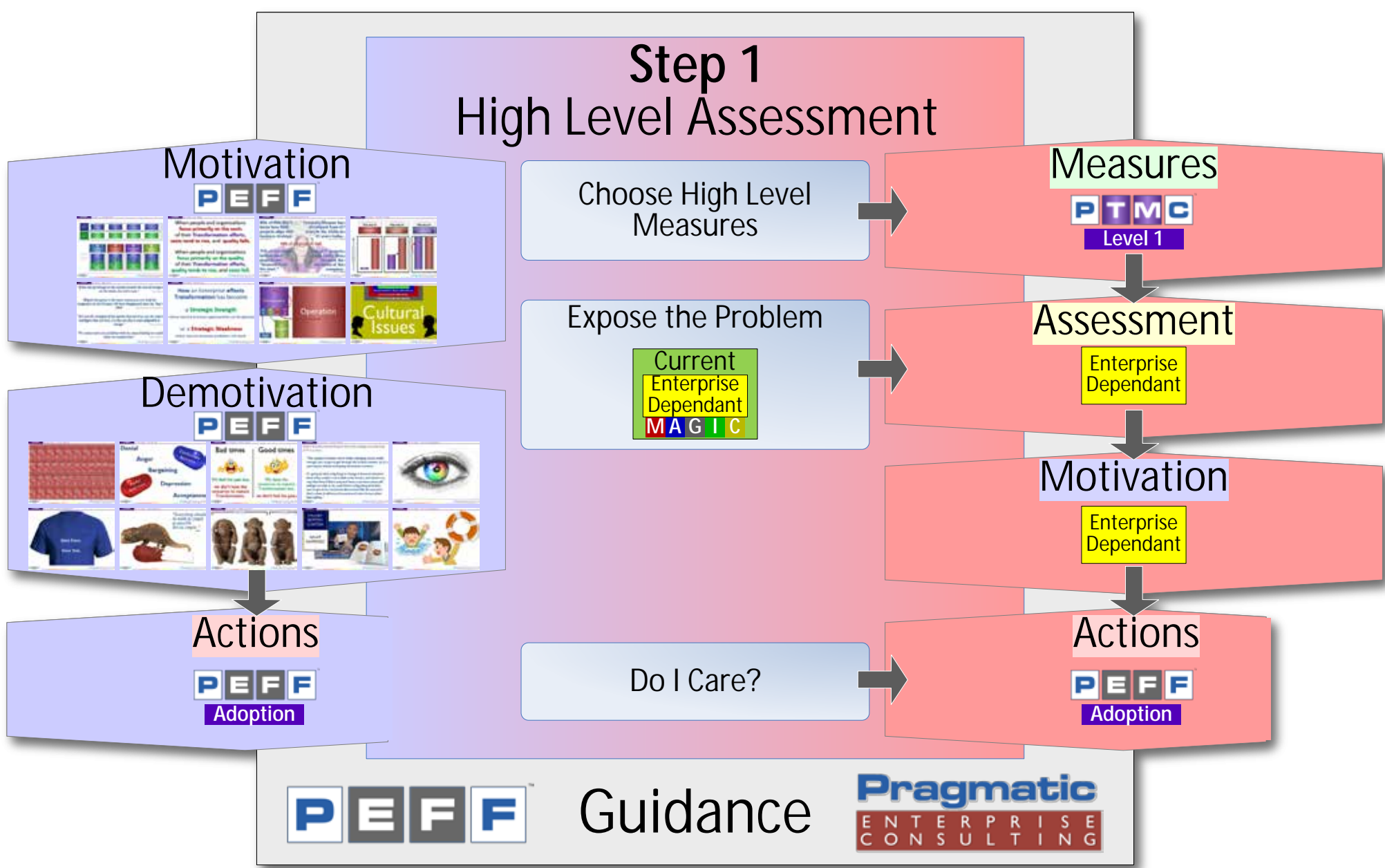

**Keypoint**  
Getting a high level assessment is the best way of getting a handle on your Transformation Capability.

**Adoption**  
C-Suite: Follow the 1st step in PEFF for maturing your Transformation capability.

# What should you use to do an initial high level assessment of an Enterprise's Transformation Capability?

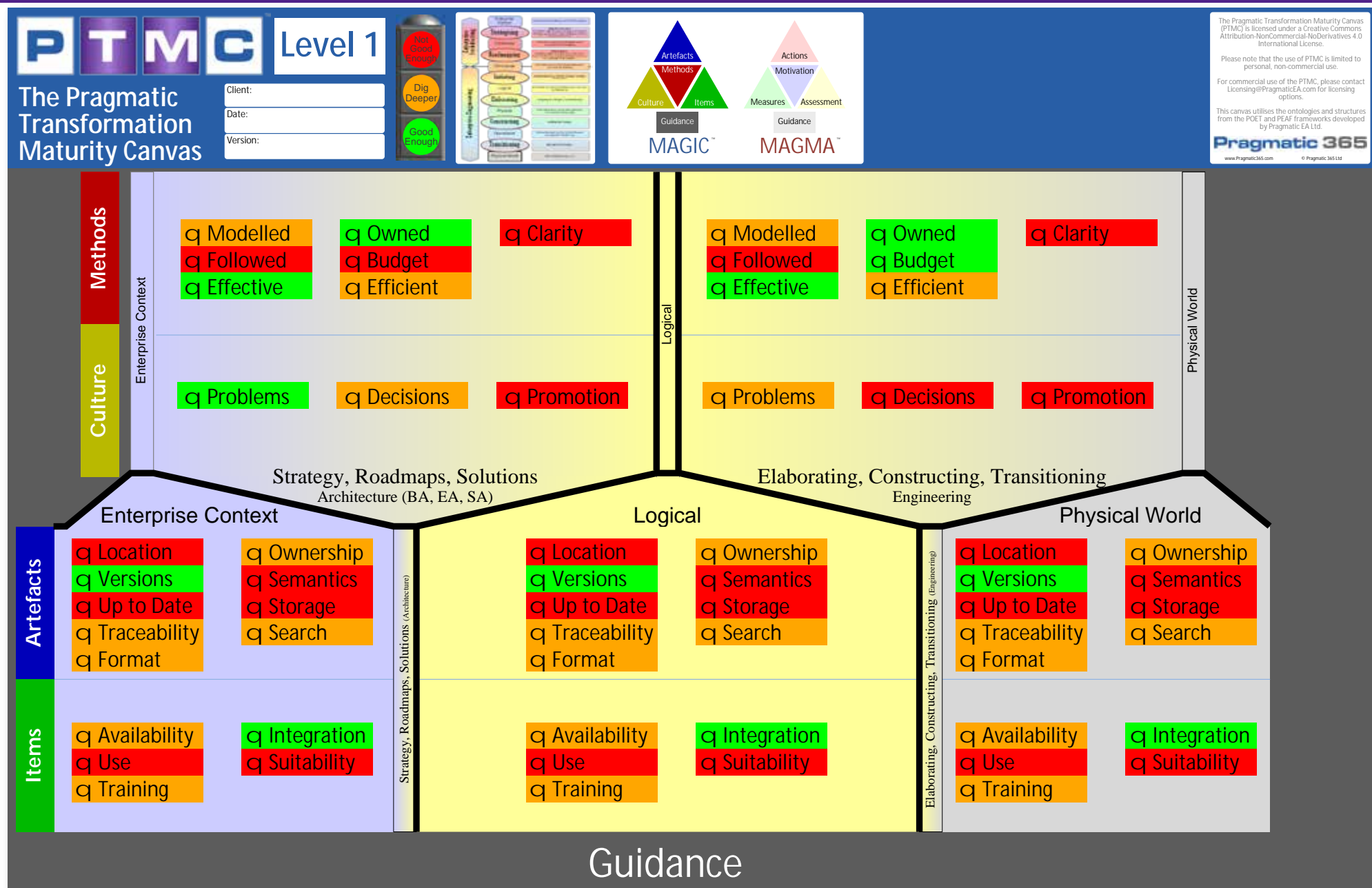

**Keypoint**  
Use PTMC Level 1 to determine if there are areas you need to dig into.

**Adoption**  
C-Suite: Instigate an initiative to use the Level 1 PTMC to perform a high-level assessment of the Enterprise's Transformation Capability.

What is the second step in Adopting any of Pragmatics Frameworks?

Roadmapping

Contextual

Step 2

Medium Level  
Assessment

Conceptual

**Keypoint**  
A medium level evaluation will tell you enough, for you to decide if you want to proceed.

# When Adopting POET, what are the fundamental Actions in Step 2?

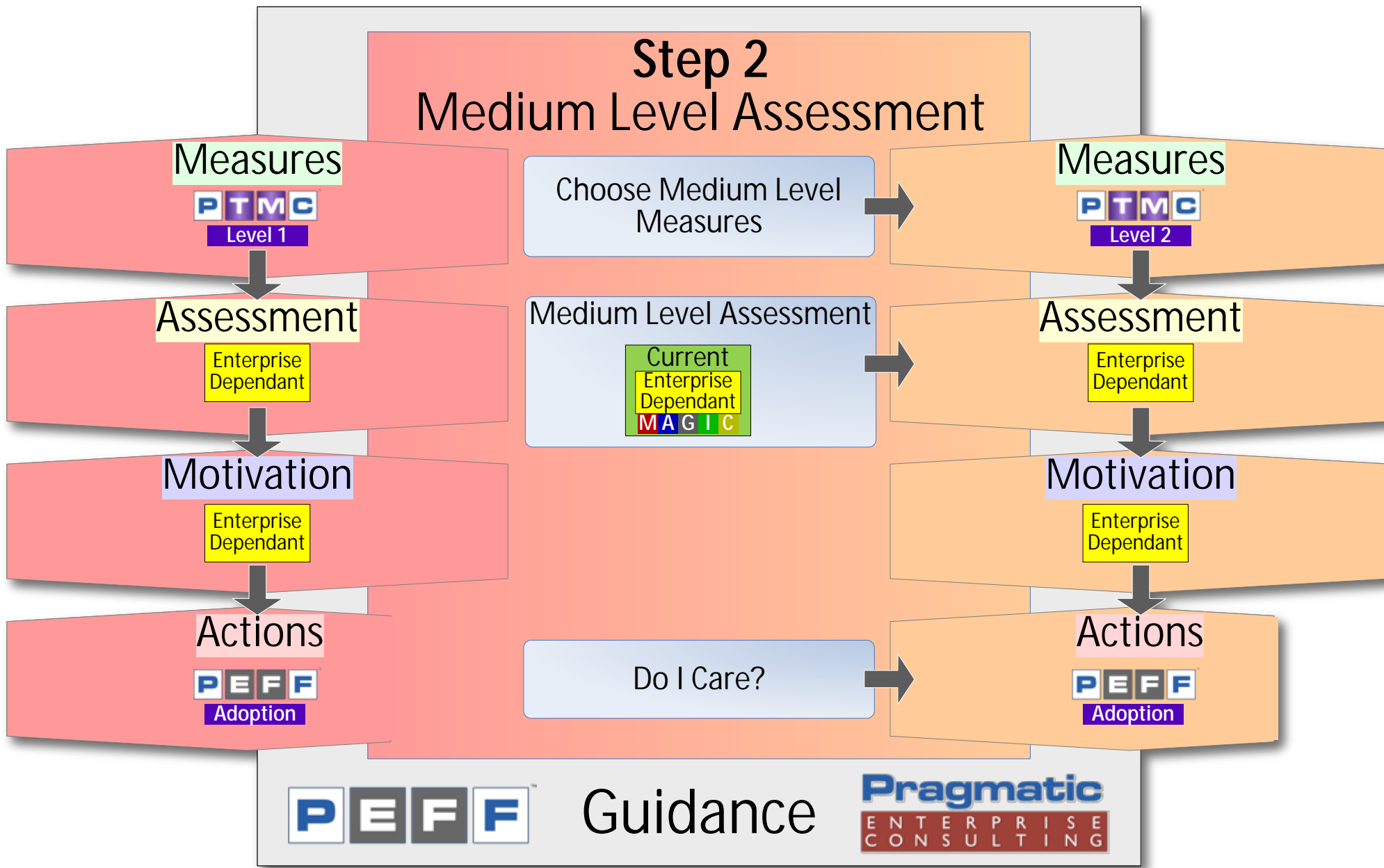

**Keypoint**  
The PTMC is key to being able to Pragmatically assess your Transformation Capability.

**Adoption**  
EA Project Team: Follow the 2nd step in PEFF for maturing your Transformation capability.



# What should you use to do a medium level assessment of an Enterprise's Transformation Capability?

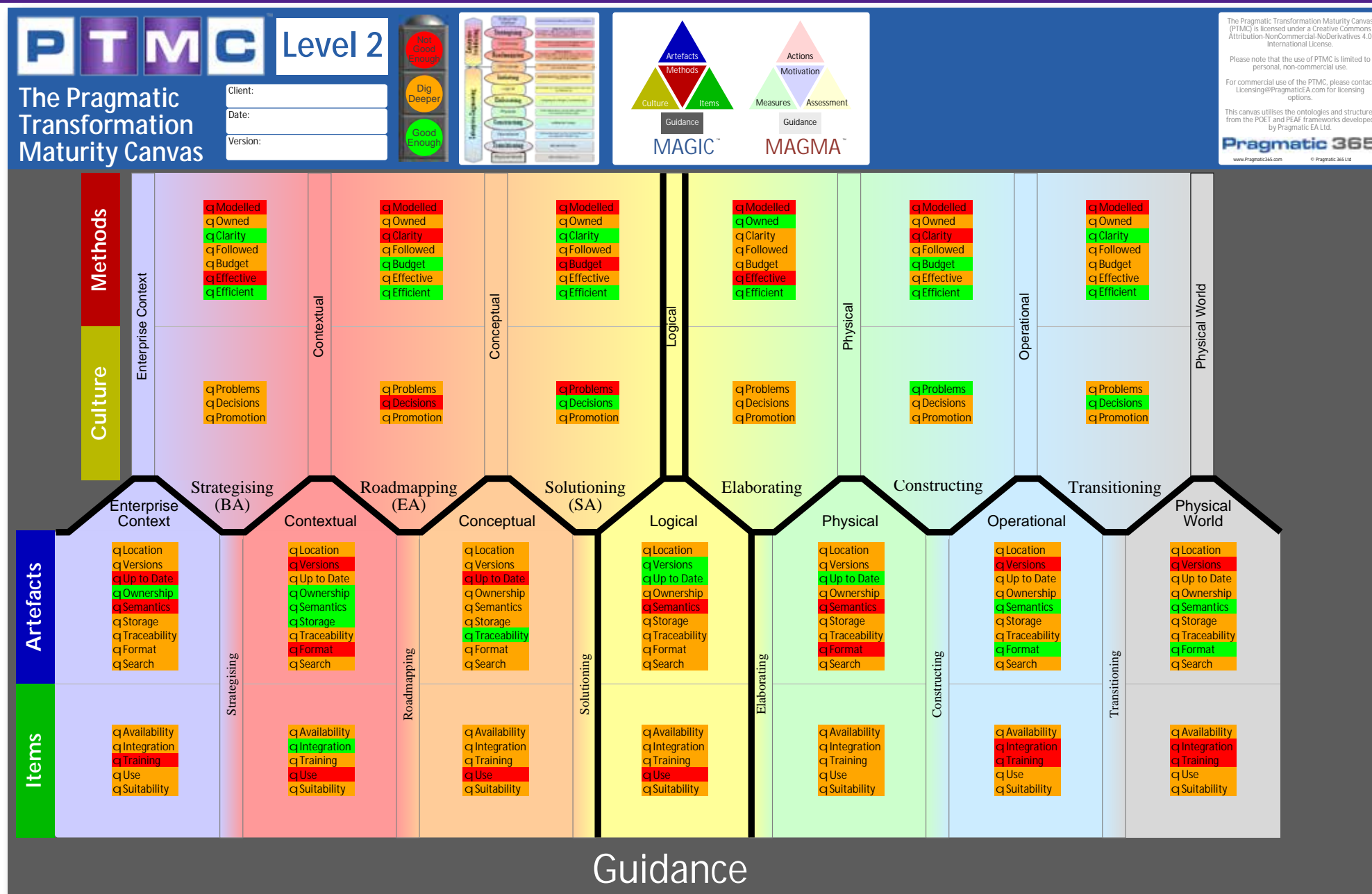

**Keypoint**  
Use PTMC Level 2 to determine which Phases and Level need most attention.

**Adoption**  
Management: Instigate an initiative to use the Level 2 PTMC to perform a medium-level assessment of the Enterprise's Transformation Capability.

# What is the third step in Adopting Pragmatics Frameworks?

Solutioning

Conceptual

Step 3  
Detailed  
Assessment

Logical

**Keypoint**  
A detailed assessment will tell you if you need to kick off other initiatives.

# When Adopting POET, what are the fundamental Actions in Step 3?

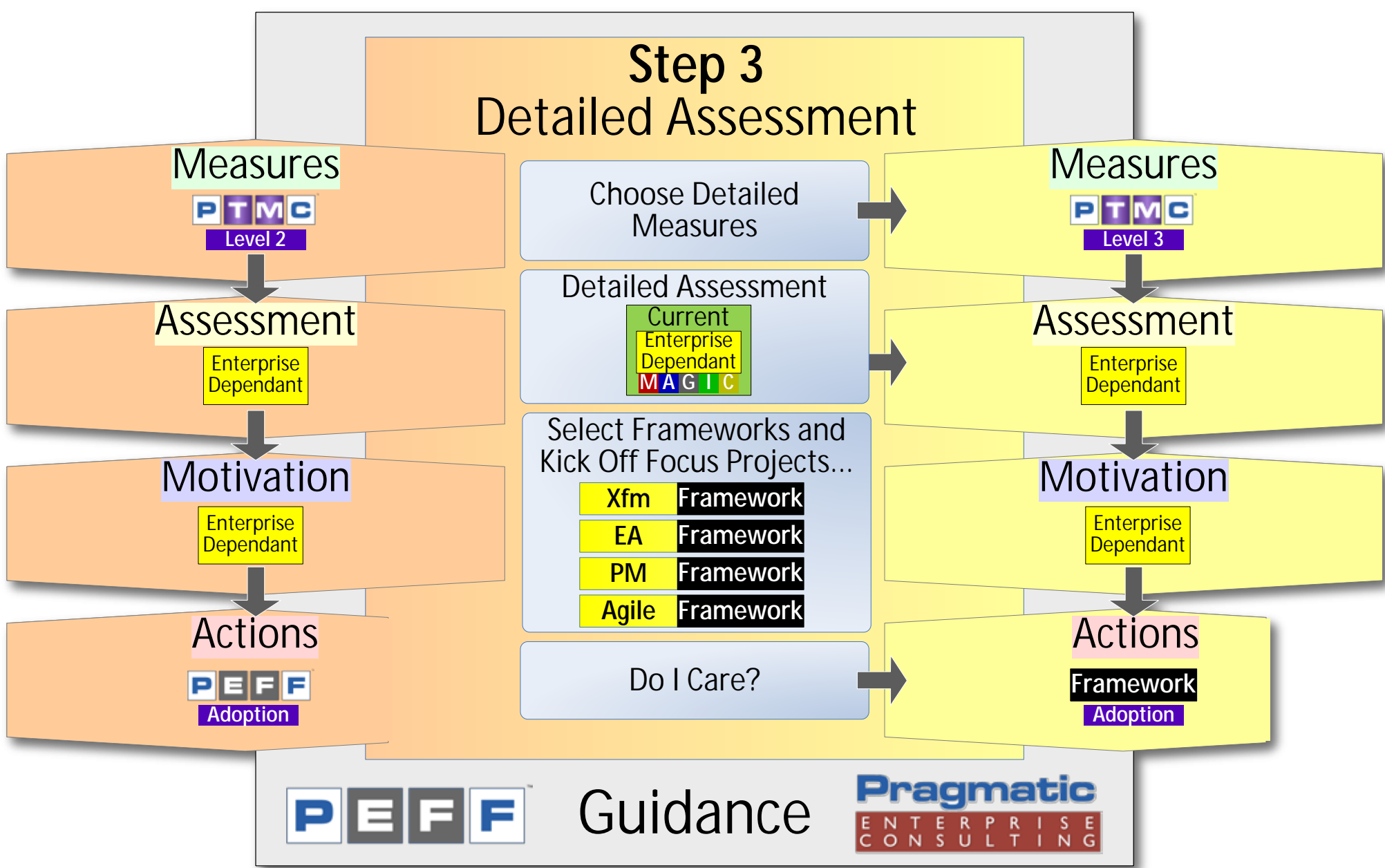

**Keypoint**  
 Kick off more detailed projects if needed.

**Adoption**  
 EA Project Team: Follow the 3rd step in PEFF for maturing your Transformation capability.





# What does the APPENDIX section contain?

# APPENDIX

## Keypoint

The Appendix section contains information on the background of PF2, POET, PEAFF and the author.

# Why did Pragmatic EA create the Pragmatic Frameworks?

WHY?

- We Care About Enterprises
- We Care About the People who Direct, Operate, Transform and Support Enterprises

WHEN?

-  •  • 

WHERE?

- Born from Observing Failure

HOW?

- 150,000 Hours of Thinking
- 20,000 Hours of Creating

USING  
WHAT?

- Architecture, Engineering, Altruism
- Honesty, Integrity, Persistence, Passion
- Common Sense, Logic

**Keypoint**  
Use POET and PEAFF to make sure you don't make the mistakes that cause 90% of all EA initiatives to fail.

# Who created the Pragmatic Frameworks?

- Kevin Lee Smith
- 40 Years in all phases of Enterprise Transformation
- MBTI: (INTJ) Mastermind,  
(INTP) Architect
- DISC: (7414) Result-Oriented
- Belbin: Plant, Shaper



## Keypoint

Use people for the type of person they are, not the type of person you want them to be. If we were all the same, nothing would ever get done.



# What are the Pragmatic Keys to Success?



**Keypoint**  
All  
Pragmatic  
books  
contain a  
Keypoint  
section.





# Summary

- PF2 introduces the Companies and Frameworks that are part of the Pragmatic Family.
- The Introduction section of PF2 introduces the companies that are part of the Pragmatic Family.
- Pragmatic 365 is a non-profit research company. Pragmatic EC is a consulting company.
- Most consultancies only want to sell you fish. Pragmatic will teach you how to fish.
- Use Pragmatic Frameworks (for free) to improve your Enterprise.
- PEAFF Certified training, provides everything to enable you to adopt PEAFF.
- PEAFF Focused Workshops, allow you to focus on specific areas.
- Access to the Pragmatic Publishing Platform is granted by graduating from an Instructor led course.



# Summary

- P3 allows Enterprises to easily produce and maintain their own Frameworks and publish them to books, their intranet and mobile devices.
- P3 is a component based authoring system.
- The Frameworks section of PF2 introduces the Frameworks that are part of the Pragmatic Family.
- To understand the whole, you first must understand the whole.
- The Pragmatic Family of Frameworks are all about Connecting the DOTS™.
- Pragmatic Frameworks are Pragmatic, Well-defined, Complete, Interlocking, Inheritable and Extensible.
- Pragmatic Frameworks were designed to be modified.
- P3 inherits from POET inherits from PF2.



# Summary

- PEEF provides the Context for POET provides the Context for PEEF.
- Pragmatic Frameworks were mostly influenced by the thinking of Deming and Zachman.
- POET grew out of things originally in PEEF, that applied to all of the Transformation space, not just the EA part.
- PEEF - The Pragmatic Enterprise Fundamentals Framework.
- PEEF allows an Enterprise to define and put in place fundamental Ontologies used throughout an Enterprise.
- POET - The Pragmatic Operating model for Enterprise Transformation.
- POET allows you to Strategically guide the Tactical changes, to the Transformation capability of your Enterprise.
- POET allows an Enterprise to take a coherent and holistic view of the Transformation part of your Enterprise.



# Summary

- POET allows an Enterprise to Tactically improve parts of Transformation, in the context of the Strategic whole.
- PEAf - The Pragmatic Enterprise Architecture Framework.
- POET allows you to Strategically guide the Tactical changes, to the Transformation capability of your Enterprise.
- PEAf allows an Enterprise to take a coherent and holistic view of the Strategising and Roadmapping (EA) Transformation phases of your Enterprise.
- PEAf allows an Enterprise to Tactically improve parts of EA, in the context of the Strategic whole.
- PTMC - The Pragmatic Transformation Maturity Canvas.
- PTMC allows an Enterprise to assess the fitness of the Transformation Capability of your Enterprise.
- The PTMC allows an Enterprise to Strategically assess its Transformation Capability, so it can Tactically mature it.





# Summary

- The PTMC allows you to Pragmatically assess the Transformation capability of your Enterprise.
- POED - The Pragmatic Operating model for Enterprise Direction.
- POED allows you to Strategically guide the Tactical changes, to the Direction capability of your Enterprise.
- POEO - The Pragmatic Operating model for Enterprise Operation.
- POEO allows you to Strategically guide the Tactical changes, to the Operation capability of your Enterprise.
- POES - The Pragmatic Operating model for Enterprise Support.
- POES allows you to Strategically guide the Tactical changes, to the Support capability of your Enterprise.
- PEEF - The Pragmatic Enterprise Engineering Framework.



# Summary

- POET allows you to Strategically guide the Tactical changes, to the Transformation capability of your Enterprise.
- POET and PEAf bridge the chasm between Zachman and TOGAF.
- People incorrectly think Pragmatic Frameworks are either too high level and conceptual or incorrectly think they are too large and detailed.
- Key Framework comparison criteria: Strategic vs Project, Enterprise vs IT, Detail vs Usability.
- Raw Scores given by Pragmatic show PEAf in the lead.
- The EA framework you choose, depends on what you want from your EA framework.
- If you favour Project guidance and Detail, rather than Strategic guidance and Usability – then TOGAF is clearly for you.
- If you favour Strategic guidance and Usability, rather than Project guidance and Detail – then PEAf is clearly for you.



# Summary

- PEAFF provides the Bootstrap to kickstart your TOGAF adoption.
- PEAFF provides the 20% (fundamentals) that yields 80% of the benefit. TOGAF provides the 80% (details), that yields 20% of the benefit.
- PEAFF covers the whole of TOGAF and more.
- Start with POET and PEAFF, and then move on to TOGAF if required.
- POET provides an Operating model for how Zachman, TOGAF, PEAFF, COBIT, ITIL (and all other Transformation frameworks) relate to each other.
- Frameworks that span multiple domains (Transformation, Operation and Support) fragment the Enterprise.
- POET/PEAFF/PEEF provides the 20% (fundamentals) that yields 80% of the benefit. TOGAF provides the 80% (details), that yields 20% of the benefit.
- The trend for TOGAF is falling. The Trend for PEAFF is rising.



# Summary

- You can't change what you don't understand. You can't understand what you can't see.
- In the Zachman Framework/Ontology, the Deployer perspective is missing.
- Use POET as a conceptual guide.
- Use POET as a Contextual / Conceptual guide. Use PEAFF as a logical guide.
- Fundamentals are fundamentally important. Doh!
- The Language section of PEAFF introduces fundamental terminology that is used throughout Pragmatic's Frameworks.
- Be ever vigilant of the hidden confusion that language can create.
- Everything is a System.





# Summary

- The Word Enterprise does not mean “large” or “large IT” or “senior”. It is a general noun.
- There is no hidden connotation to Pragmatic’s use of the word “Transformation”.
- A Framework is an expression of Best Practice comprising information in at least one area (Methods, Artefacts, Guidance, Items, Culture) and optionally information regarding its Adoption.
- Theory is just as important as Practice
- Colour = Information = Understanding.
- Concentrate on the 20% that causes 80% of the good effects.
- Just doing the right things is no longer enough. You also need to do them in the right way.
- Important Non-Urgent work, is more important than Important Urgent work.



# Summary

- Fundamentals are the foundation on which to build things.
- Without thinking, there can be no innovation.
- Empowerment always beats command and control.
- Anything is pointless, unless it is sustainable.
- The Ontologies section of PEFF introduces fundamental ontologies that are used throughout Pragmatic's Frameworks.
- Methods, Artefacts, Guidance, Items and Culture (MAGIC) is a Structural Ontology
- Methods are executed by Culture (people) and/or Items (things) to transform Artefacts.
- Work is done at the intersection of Phases, Disciplines and Artefacts.



# Summary

- Motivation, Actions, Guidance, Measures and Assessment (MAGMA) is a Transformational Ontology
- Measures lead to Assessments lead to Motivation, leads to Actions
- Direct, Operate, Transform and Support (DOTS) is an Enterprise Ontology
- Direction drives Operate (supported by Transform and Support) which takes things from the Context and puts things into the context.
- There are some very key things that should happening in all Enterprises but are not in most.
- Fragmenting Strategically important parts of an Enterprise (DOTS) , all over the Enterprise results in a Strategic loss of focus
- Grouping Strategically important parts of an Enterprise (DOTS) together, results in excellent Strategic focus
- The Adoption section of PEFF defines the first 3 steps common to adopting any Pragmatic Framework.



# Summary

- Maturity models are useful for Enterprises assessing their capabilities.
- The PTMC enables Transformation capability assessment, as well as post project reviews.
- The PTMC can be populated with post-it notes, a cloud based tool or online forms.
- A PTMC report provides a high level traffic lights view of the maturity of your Enterprise Transformation Capability.
- When adopting a Framework, value gained will always go down initially.
- Use EMMA to adopt frameworks.
- The Adoption of any Framework is a Transformation, and therefore the Phases defined in POET are used.
- Adopting POET is a cascade of MAGMA which ultimately transforms the MAGIC of the Transformation Capability.



# Summary

- **EVERYTHING** is dependant upon the C-Suite caring enough.
- The most important thing is **NOT TAKING** the first step. It's **DECIDING** to take the first step.
- If no one cares, there is no point in trying to use Pragmatics Frameworks to mature your Transformation Capability.
- "The Business" and IT are so intrinsically linked, a new paradigm is needed. That paradigm is DOTS.
- We have seen the enemy, and the enemy is us (Management).
- 70% of all change will continue to fail, unless you change how you change.
- It's not what you do, it's the way that you do it. (And that's what gets results.)
- Jack Welch, Darwin and Einstein do have a point!





# Summary

- How an Enterprise effects Transformation is becoming a Strategic Strength or a Strategic Weakness.
- The Transformation of Transformation (ToT) is using a Transformation capability, to mature a Transformation capability.
- The Problems you face or Opportunities you wish to exploit, with respect to the Culture, drive the changes you need to make.
- Use PTMC Level 0 to conduct a free flowing gathering of ideas.
- PEF/POET/PEAF don't replace what you do. They make the MAGIC your do more Effective, Efficient, Agile and Sustainable.
- Domain Blindness: People simply cannot see the Transformation domain.
- Red Pill: If you do not want to swallow the Red Pill, no one will force you
- Timing Paradox: When maturation is needed, there are no resources to effect the change. When there are resources to effect the change, there is no requirement to do so.



# Summary

- **Management/Workers Paradox:** Workers experience the problems on a daily basis. Management says there are no problems,
- **Process Paradox:** To get the change on the radar, we are battling against the currently flawed process. If the current process was not flawed, we would not need to mature it.
- **Unconscious Degradation:** The Effectiveness, Efficiency, Agility and Durability of a Transformation capability degrades slowly over time, and therefore can be easily missed.
- **False Accomplishment:** Many Enterprises think they have already “done” some kind of maturation when in fact they have not.
- **Oversimplification:** Many Enterprises have a compulsion to reduce things to the point of uselessness.
- **Reality Avoidance:** Many Enterprises do not want to hear that their Transformation Capability has serious problems, and many Consultancies do not want to tell them.
- **It’s Just Not Sexy:** Many Enterprises are not interested in maturing their Transformation Capability because it’s just not “sexy”.
- **Fix the Fundamentals:** Don’t spend all your time saving drowning children. Spend some of your time preventing them from falling into the river as well.



# Summary

- A quick and dirty evaluation will tell you enough, for you to decide if you want to proceed.
- Getting a high level assessment is the best way of getting a handle on your Transformation Capability.
- Use PTMC Level 1 to determine if there are areas you need to dig into.
- A medium level evaluation will tell you enough, for you to decide if you want to proceed.
- The PTMC is key to being able to Pragmatically assess your Transformation Capability.
- Use PTMC Level 2 to determine which Phases and Level need most attention.
- A detailed assessment will tell you if you need to kick off other initiatives.
- Kick off more detailed projects if needed.



# Summary

- Use PTMC Level 3 to narrow down specific areas that need some TLC.
- The Appendix section contains information on the background of PF2, POET, PEAFF and the author.
- Use POET and PEAFF to make sure you don't make the mistakes that cause 90% of all EA initiatives to fail.
- Use people for the type of person they are, not the type of person you want them to be. If we were all the same, nothing would ever get done.
- All Pragmatic books contain a Keypoint section.



What does PragmaticEA do?

# Pragmatic 365

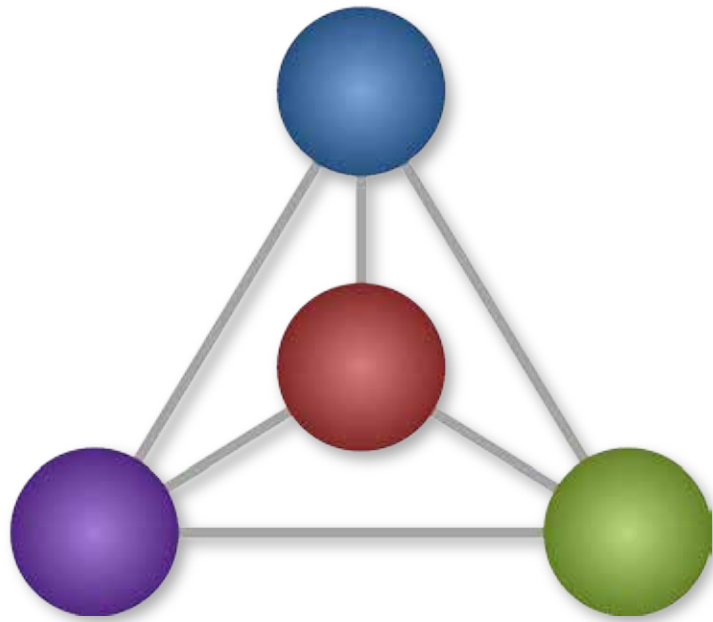

Connecting  
the DOTS